

FACTORY AUTOMATION

ENERGY-SAVING SUPPORTING DEVICES



GLOBAL IMPACT OF MITSUBISHI ELECTRIC



Through Mitsubishi Electric's vision, "Changes for the Better" are possible for a brighter future.

Changes for the Better

We bring together the best minds to create the best technologies. At Mitsubishi Electric, we understand that technology is the driving force of change in our lives. By bringing greater comfort to daily life, maximizing the efficiency of businesses and keeping things running across society, we integrate technology and innovation to bring changes for the better.

Mitsubishi Electric is involved in many areas including the following

Energy and Electric Systems

A wide range of power and electrical products from generators to large-scale displays.

Electronic Devices

A wide portfolio of cutting-edge semiconductor devices for systems and products.

Home Appliance

Dependable consumer products like air conditioners and home entertainment systems.

Information and Communication Systems

Commercial and consumer-centric equipment, products and systems.

Industrial Automation Systems

Maximizing productivity and efficiency with cutting-edge automation technology.

OVERVIEW

Energy-Saving Concepts	3
Introduction of Mitsubishi Energy Saving Products	5
System up for Energy Measuring System	7
Energy Measuring Unit “EcoMonitorLight”	9
Energy Measuring Unit “EcoMonitorPlus”	11
Programmable Logic Controller MELSEC-Q Series Energy Measuring Module / Insulation Monitoring Module	13
Electronic Multi-Measuring Instrument	15
MDU Circuit Breakers	17
Energy Saving Data Collecting Server “EcoWebServerⅢ”	19
Example of Energy Monitoring System	23
MC Works64	25
INVERTER FR-F800	27

Energy-saving Concepts

- What do you need if you are to go on a diet? Measuring your weight and making a graph of the weight fluctuation can lead to success in a diet. The same holds for saving energy. Measuring energy and analyzing current factory conditions using Visible Management is the starting point to conserve energy.
 - To save energy, measuring and managing production energy use is necessary.
- ➡ Measurement (understand and analyze current conditions) and improvement activities are necessary to save energy.

Steps for energy-saving activities

Energy-saving activities can ultimately lead to improved factory productivity:

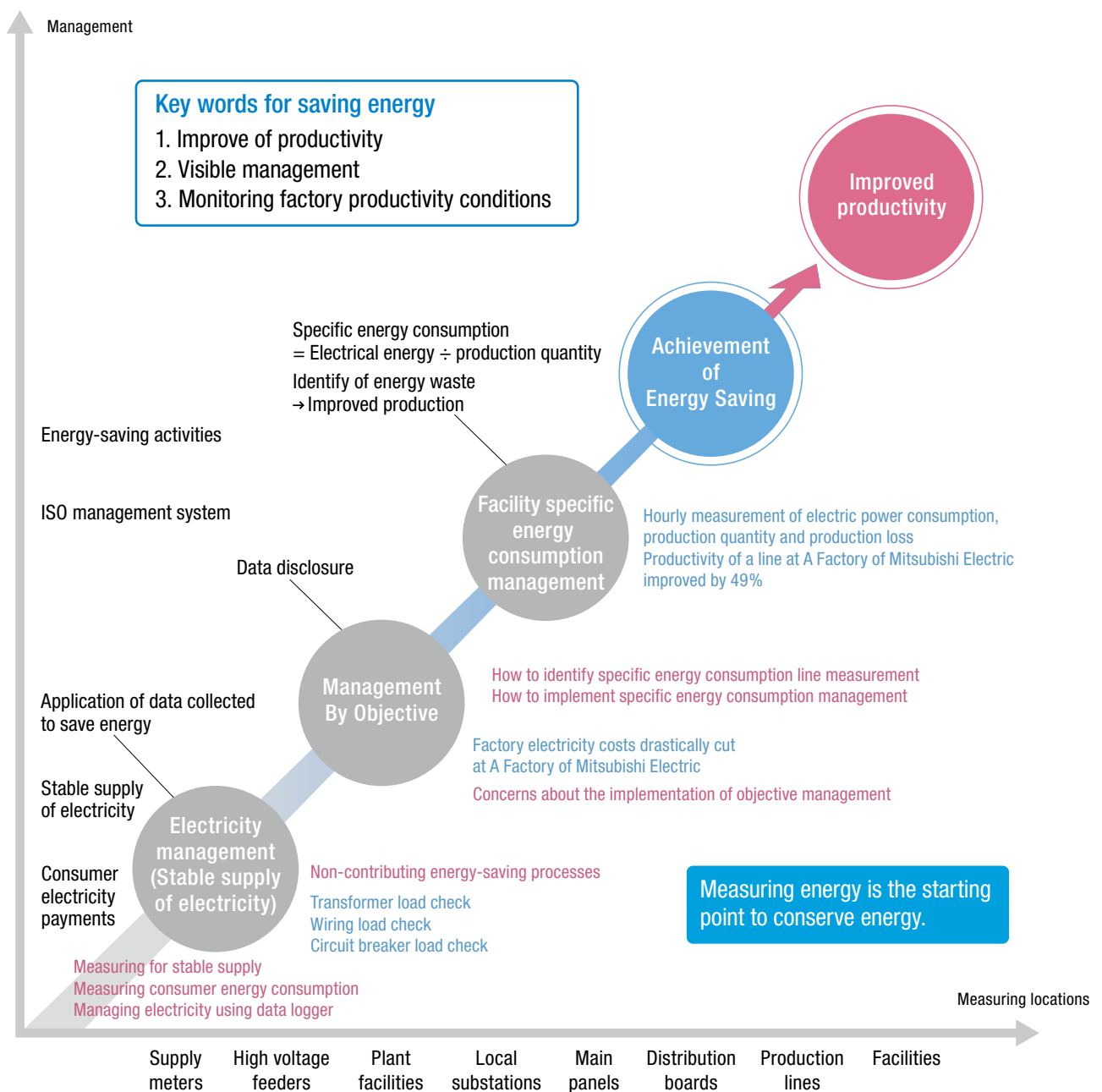



Electronic Energy Measurement



Effects of Energy Saving

Increase productivity

Productivity under normal conditions can be analyzed by managing specific consumption (Electrical power/production quantity). For example, one reason of worsening specific consumption can be facility breakdown. By finding the cause, the specific consumptions can be reduced, which leads to improvement in productivity. Moreover, surveillance of upper/lower limits contributes to maintaining electrical machines and equipment.



Increase Energy Efficiency

Effective energy saving activities start from grasping the current conditions by making energy usage amount visible. Efficiency of energy usage becomes possible by thorough energy management by department, and usage by specific consumption management by each line facility.

[At factories]



- Realize "visible management" by building a model factory for energy saving
- Realize "visible management" where everyone participates by disclosing data
- Finding waste by specific consumption management at each facility
- Finding waste by measuring facility management
- Strengthen specific consumption management by time, line and facility

[At buildings]



- Realize "visible management" where everyone participates by data disclosure
- Implement and promote energy saving activities by Management By Objective
- Strengthen each floor's time and energy usage management



Increase Production Process Efficiency

By measuring electrical power on a short cycle (1 sec, 1 min etc), how each load changes throughout the manufacturing process can be observed. You can analyze if there is any unprofitable waiting time or unnecessary load current running during a waiting time.

Example at A Factory of Mitsubishi Electric
Production specific consumption cut by **14.6%**
(in 2004, compared to 1990)

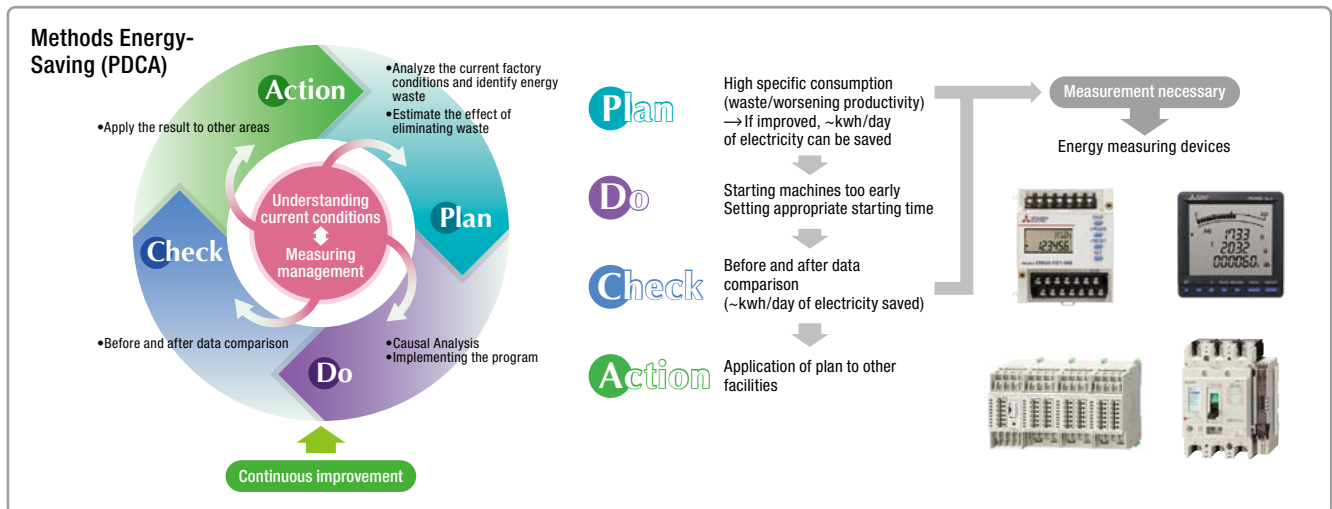

Process of Energy Saving

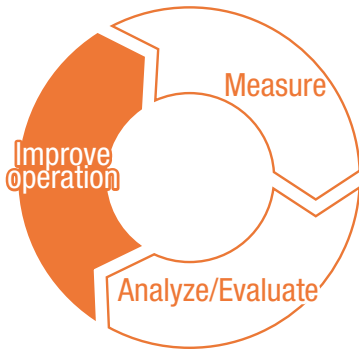

To maintain more efficient energy/electricity savings, it is important to repeatedly
Measure ⇒ Analyze/Evaluate ⇒ Improve operation.

Measure Energy Saving-Supporting Device

Energy Measuring Unit EcoMonitorLight



➤ P 9.10

Using the built-in LCD screen, the energy consumption measured per unit can be displayed and the measurement value indicated. Since the RS-485 (MODBUS® RTU) communication function is incorporated, when using the free data collection software, the present value of data being measured can be displayed on a personal computer and the CSV file acquired.

Energy Measuring unit EcoMonitorPlus



➤ P 11.12

The building block system makes it possible to add circuits if necessary. Insulation-level monitoring products can be used to measure the resistance fraction of leakage current (Ior) as well as for preventive maintenance of facility equipment.

Electronic Multi-Measuring Instrument



➤ P 15.16

Equipped with a full lineup of features, such as multiple measuring elements, and output and transmission functions, this indicator supports the realization of measuring and monitoring systems and energy-saving monitoring that are user-friendly and have easy-to-see displays.

Programmable Logic Controller MELSEC-Q Series Energy Measuring Module/Insulation Monitoring Module



➤ P 13.14

Directly slotted into the programmable controller, the measurement of various energy information has never been easier. Combined with an indicator (GOT), basic-unit graphs are easily displayed.

MDU Circuit Breakers



➤ P 17.18

The MDU Breaker is the result of integrating a circuit breaker and measurement indicator. It realizes energy-saving management support, and save both space and labor.

Analyze/Evaluate Energy Saving-Supporting Device

Energy Saving Data Collecting Server EcoWebServer III



➤ P 19.20.21.22

Energy-Saving Data Collection Server
 With a simple setting, EcoWebServer III collects data from measurement devices connected via field networks (CC-Link or MODBUS®), produces a graph and shows the present value created from the corrected data on a web browser. It easily enables the data analysis required for saving energy.

MC Works64



➤ P 25.26

SCADA Software MC Works64 is a one-stop solution for configuring highly functional monitoring control systems capable of incorporating various Programmable logic controllers, PCs and FA equipments.

Improve operation Energy Saving Device Expecting energy saving-effect by just installing.

INVERTER FR-F800



➤ P 27

In response to demands for further energy savings, FREQROL-F800 Series fan pump inverters can control general-purpose motors (three-phase induction motors).

Mitsubishi Energy-Saving Support System

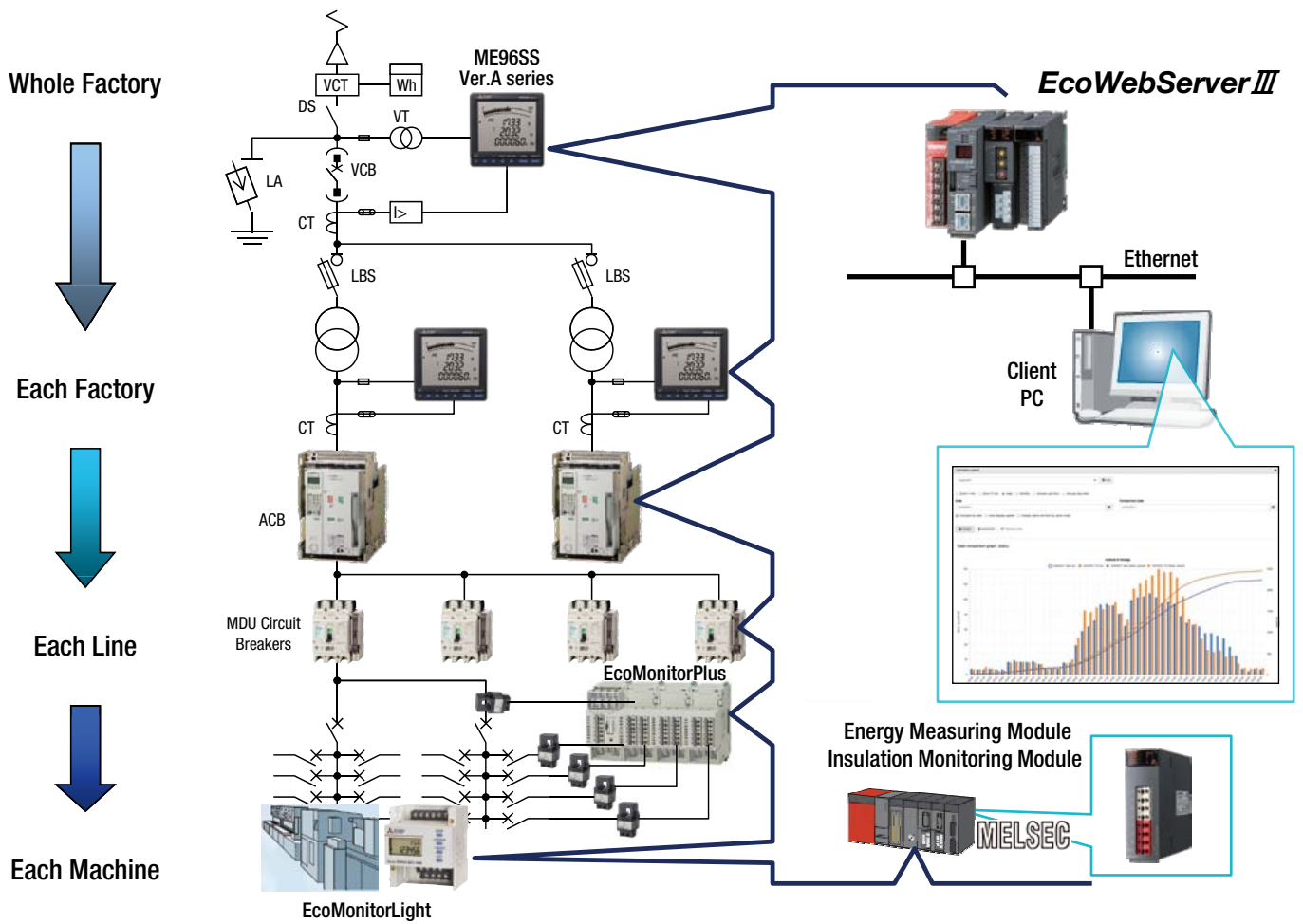

Introduction of Mitsubishi Energy Saving Products

Position map of measuring devices

		Products range			
Medium Voltage Low Voltage	Incoming panel/High voltage panel				
	Low voltage distribution board	Main breaker of secondary of transformer Feeders of low voltage distribution board			
	Branch panel	Main breaker of branch panel Feeders of branch panel			
	Equipment (Control panel)	Main breakers of control panel (Breaker of equipment)			

ME96SS Ver.A series

- ◆ Most appropriate for monitoring receiving/distribution equipment of electric power facilities. Used extensively for newly built receiving/distribution control panels.
- ◆ One device monitor four elements, mounted bar-graph display function visualizes values measured
- ◆ All models compatible with class 0.5S electrical energy measurement

EcoMonitorPlus

- ◆ Building block system allows circuit expansion
- ◆ Integration of insulation monitoring device enables measurement of electricity and leakage current with one unit

EcoMonitorLight

- ◆ Suitable for distribution board and control panel
- ◆ Easy to install with existing circuit using split-type current sensor (BD1 · HD1)
- ◆ Off-line logging with SD memory card and system construction with PLC, GOT

MELSEC-Q series Energy Measuring Module/Insulation Monitoring Module

- ◆ Direct mounting to MELSEC-Q Series base realizes space-saving control panel
- ◆ Communication module and communication program not required, realizing cost reduction
- ◆ Insulation monitoring module capable of measuring electricity leakage of dual circuits introduced

System up for Energy Measuring System

Scalable system expansion is possible depending on the number Mitsubishi Electric energy-saving support devices connected to manage functions and measurements.

1. Visual Monitoring

- Monitor measuring devices installed in distribution boards and control panels.
- The easiest way to visualize energy consumption.

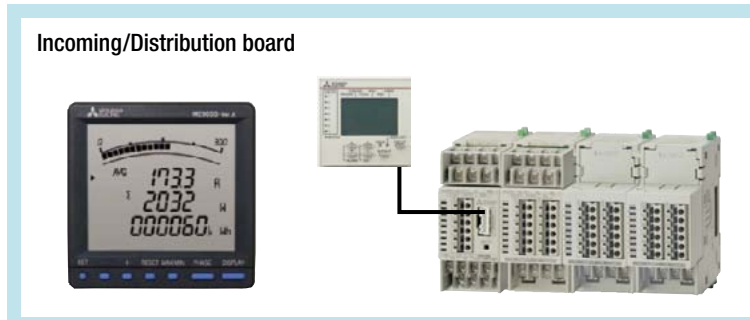

2. Data Logging (Logging unit + SD card)

- Add a logging unit in measuring device and collect the data through SD card.
- To save labor hour of visual monitoring.

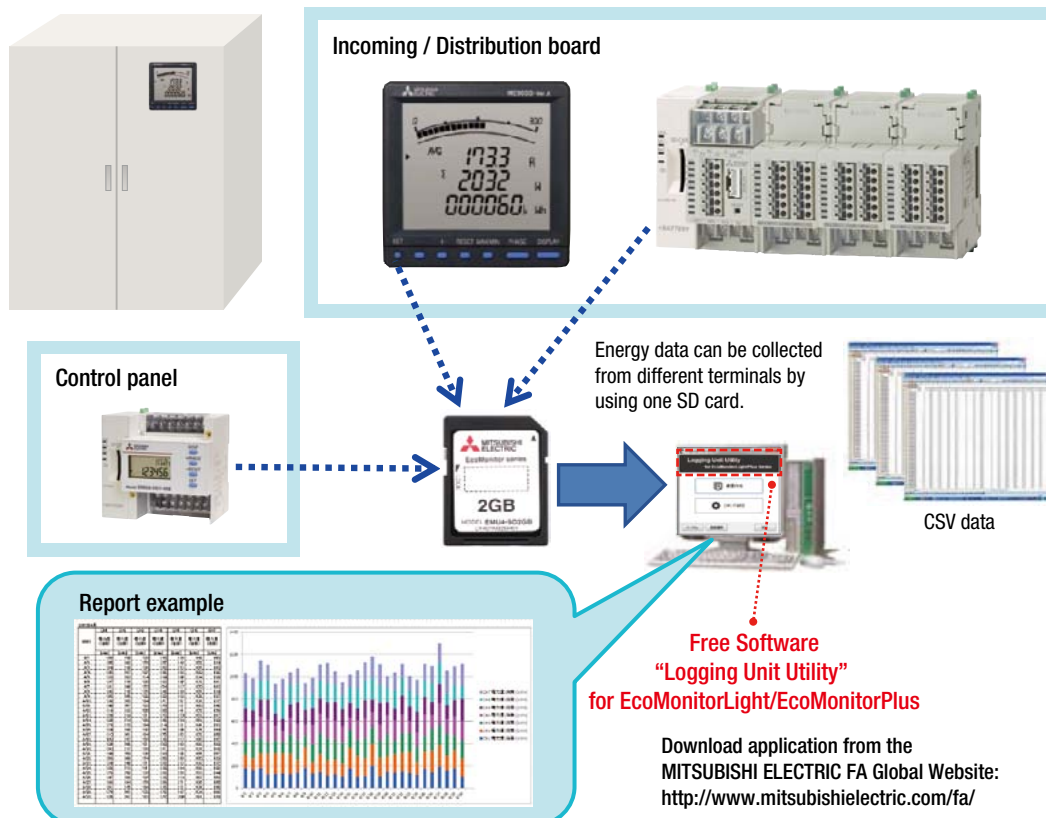

3. System networking

PC monitoring with Modbus communication

- Easily build an energy measuring system using Modbus communication.
- Collect energy data using a PC and data acquisition software.

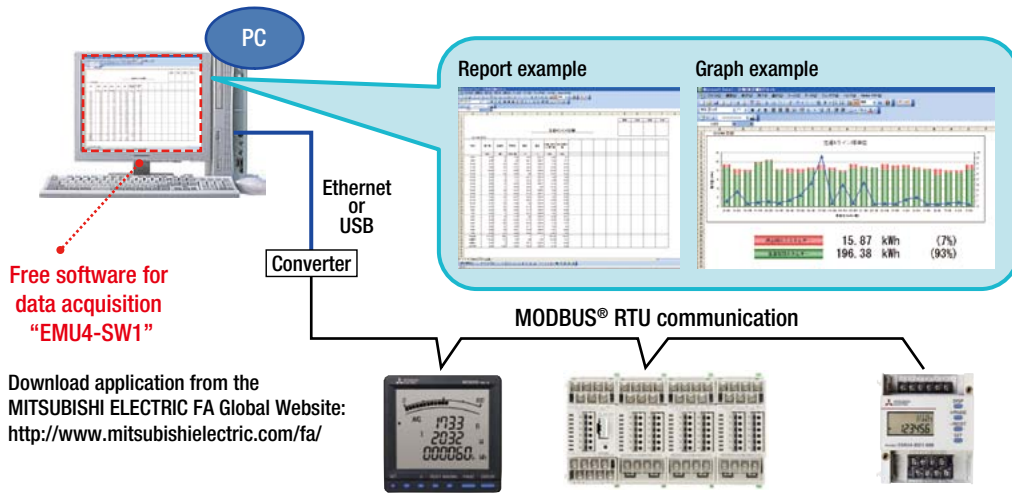

Monitoring by GOT

- Energy visualization for each facility possible using GOT (via MODBUS® RTU communication)

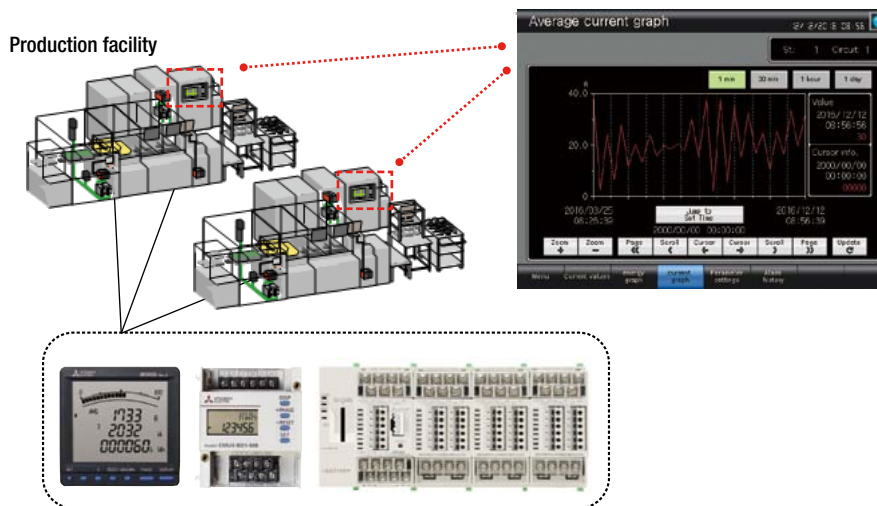

Energy Visualization System (EcoWebServer III)

- Energy measurement graph can be shown through factory LAN by using EcoWebServer III
- Remote monitoring of machines and line status can be shown by PC

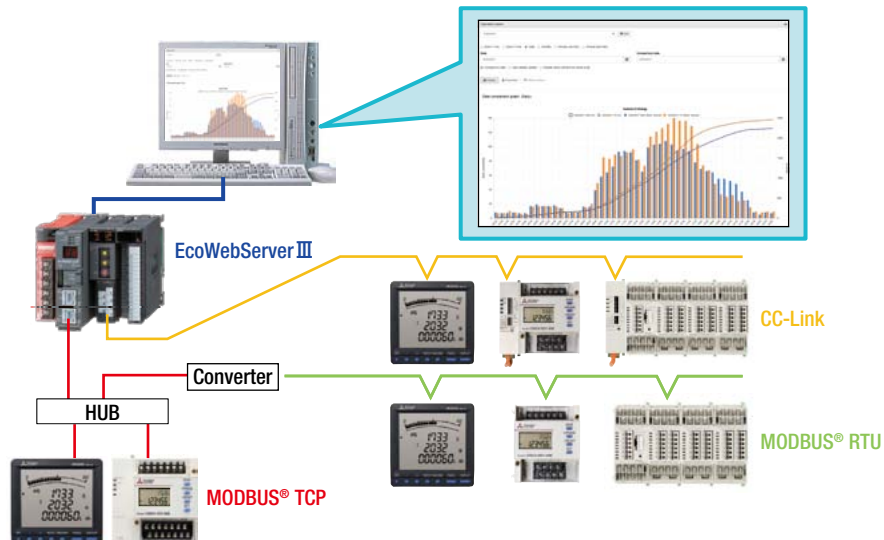

Energy Measuring Unit EcoMonitorLight

With a single circuit and an integrated display, EcoMonitorLight is ideal for simple and easy measuring. This product is effective for eliminating energy waste and confirming the benefits of energy-saving countermeasures by visualizing the energy consumed by air conditioning and lighting systems, and production equipment.

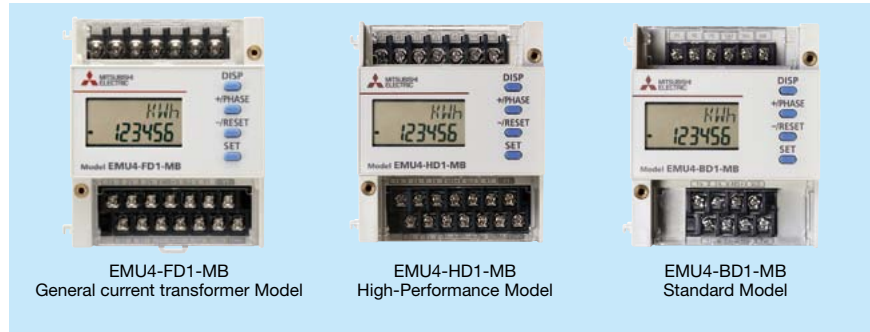

1. EcoMonitorLight Features

1. Measures and displays energy data on a single unit

- Easy setting/Easy management
Equipped with a setting switch and built-in LCD display, setting, measuring and displaying energy measurements are all possible using one unit.

2. MODBUS® RTU communication built-in

- EMU4-SW1 data acquisition software
MODBUS® RTU communication enables current value, output form, measurement device settings and other information to be displayed and set with ease on a computer. Data acquisition software can be downloaded for free from the MITSUBISHI ELECTRIC FA Global Website: <http://www.mitsubishielectric.com/fa/>
- Host system connectivity
With the built-in MODBUS® RTU communication function, EcoMonitorLight can be easily connected with EcoWebServer III^{*1} or other host system.
*1 MODBUS® TCP ↔ MODBUS® RTU converter is necessary.
- Direct connection to display device (GOT)
MODBUS® RTU communication enables direct connection with display device (GOT).



3. Expand after adding optional unit

- Logging unit
Connect a logging unit to store various logging data (such as power, current and voltage) on a SD memory card in CSV file format.
- Communication unit
Add a MODBUS® TCP communication unit² or CC-Link communication unit to easily expand to an EcoWebServer III visualized system or other host system.
*2 Only EMU4-FD1-MB can be connected to the MODBUS® TCP communication unit (EMU4-CM-MT).

Data stored in the logging unit (SD memory card)

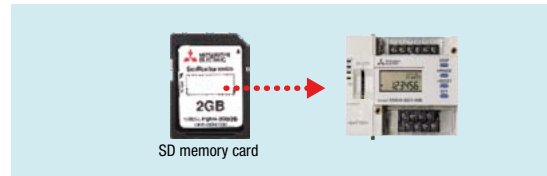

Add communication unit (MODBUS® TCP communication, CC-Link communication) to expand EcoWebServer system



Other Features

Basic Installation ① (EMU4-FD1-MB)

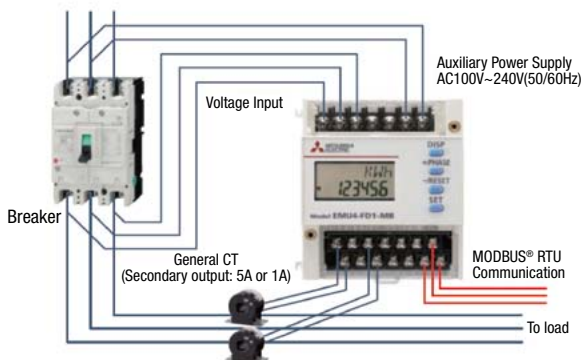

Since current input by general CT (secondary output : 1A or 5A) is possible, Mitsubishi split-type current sensor is not needed.

*1: Do not connect together more than one EMU4-FD1-MB on the secondary side of a current transformer.

*2: Do not connect together other units and EMU4-FD1-MB on the secondary side of a current transformer.

Basic Installation ② (EMU4-BD1-MB/EMU4-HD1-MB)

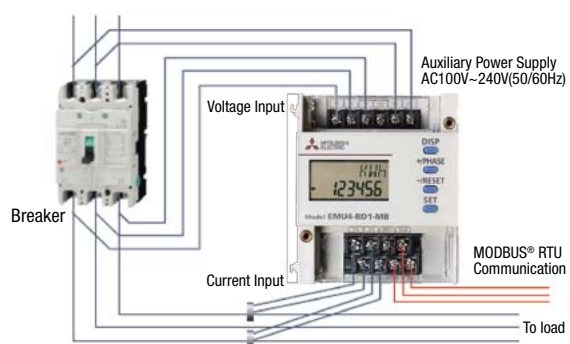

Easy installation to existing circuit by Mitsubishi spirit-type current sensors.

2. Installation Scenarios/Application Examples

Easy Energy Logging (Logging unit + SD card)

- Add a logging unit in measuring device, and collect the data through SD card.
- To save labor hour of visual monitoring.

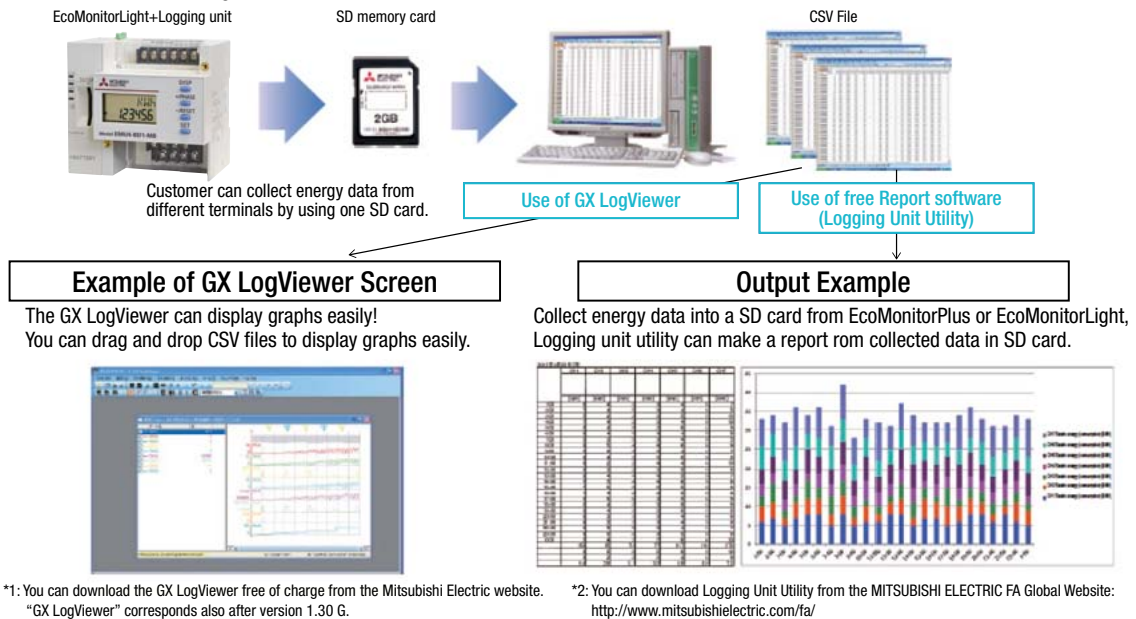

Construct a visualization system with EcoWebServer III

By building a system with MODBUS® RTU (via a converter) and MODBUS® TCP communication, measurement data can be automatically collected and remotely monitored!

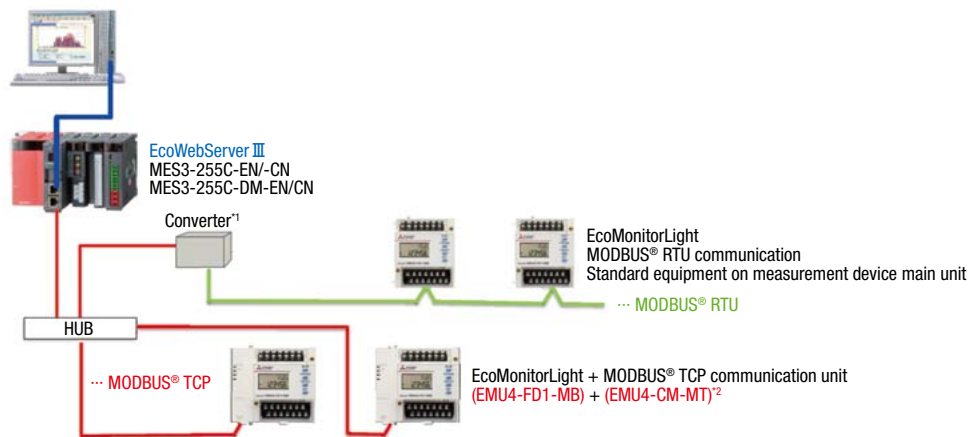

¹ MODBUS® TCP ↔ MODBUS® RTU converter is necessary
² Only EMU4-FD1-MB can be connected to the MODBUS® TCP communication unit (EMU4-CM-MT).

Item	Specifications		
Model	EMU4-FD1-MB	EMU4-HD1-MB	EMU4-BD1-MB
Phase-wire system	1P2W/1P3W/3P3W/3P4W common	1P2W/1P3W/3P3W/3P4W common	1P2W/1P3W/3P3W common
Rated voltage	Direct 110VAC, 220VAC, 440VAC available	Direct 110VAC, 220VAC, 440VAC available	Direct 110VAC, 220VAC available
Items measured	Energy, reactive energy	○	○
	Current, voltage	○	○
	Power, reactive power	○	○
	Power factor, frequency	○	○
	Apparent power	○	○
	Harmonic current, harmonic voltage	○	○
	Periodic energy	○	○
	Operating time	○	○
	Pulse count value	○	○
	CO ₂ conversion value	○	○
External input	Pulse input/contact input × 1	Pulse input/contact input × 1	-
External output	Pulse output/alarm output × 1	Pulse output/alarm output × 1	-
Communication	RS-485 (MODBUS® RTU) communication		
Data update cycle	250ms		
Standards and certifications	CE Marking, UL, KC Mark		
External dimensions	W75 × H90 × D75 (mm)		

Energy Measuring Unit EcoMonitorPlus

EcoMonitorPlus is an energy measuring unit that offers extra value depending on how it is utilized and combined to suit the application. Benefits include configuring systems to visualize energy use, supporting preventive maintenance of production equipment, and improving productivity.



1. EcoMonitorPlus Features

Basic Configuration Additional units can be gradually added to expand systems in “building block” style.

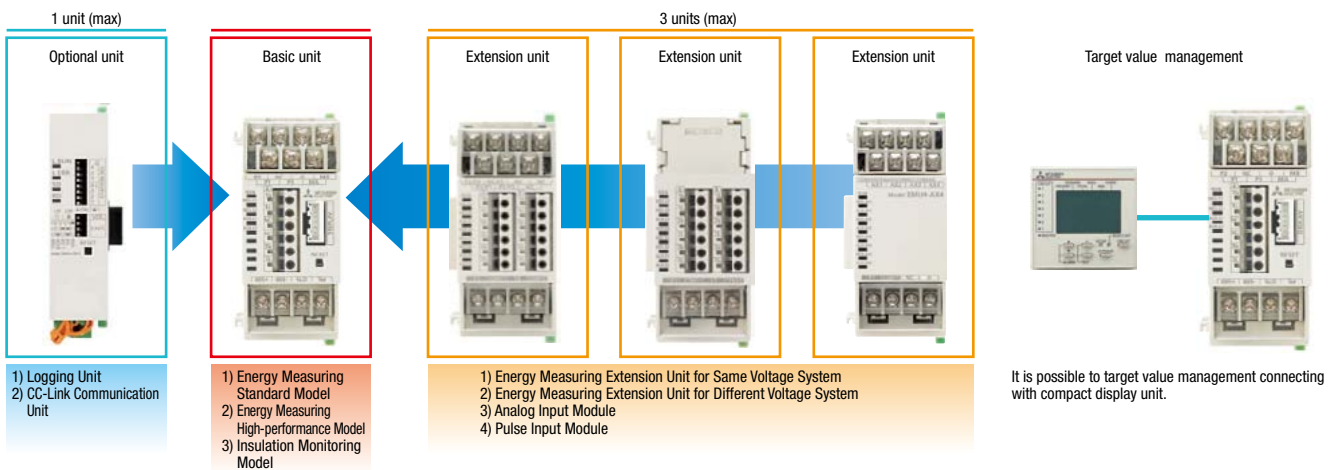

2. Lineup

<p>Basic Unit</p> <p>When you simply want to measure energy!</p> <p>Energy Measuring Standard Model EMU4-BM1-MB</p>	<p>Offers additional functions such as pulse count and 440V direct voltage input!</p> <p>Energy Measuring High-performance Model EMU4-HM1-MB</p>	<p>Great for measuring leakage current when monitoring insulation!</p> <p>Insulation Monitoring Model EMU4-LG1-MB</p>	
<p>Extension Unit</p> <p>For measuring circuits with same voltage!</p> <p>Energy Measuring Extension Unit for Same Voltage System EMU4-A2</p>	<p>For measuring circuits with different voltages!</p> <p>Energy Measuring Extension Unit for Different Voltage System EMU4-VA2</p>	<p>Great for inputting analog information!</p> <p>Analog Input Model EMU4-AX4</p>	<p>Great for inputting multiple pulse points!</p> <p>Pulse Input Model EMU4-PX4</p>

Communication

● Since MODBUS®RTU (RS-485) communication is equipped as standard, it can be connected with PLC, host system, or display device (GOT).

Optional Module

● Logging Unit

The Logging Unit enables all of the measurement data (electric energy, voltage, current, etc.) logged to be stored in CSV file format on an SD memory card.

● Communication Unit

By connecting a CC-Link Communication Unit, the EcoMonitorPlus can be easily expanded into an EcoWebServer III visualization system or programmable controller system.



Logging Unit



CC-Link Communication Unit

3. Application Examples

Various measuring needs answered with module combinations

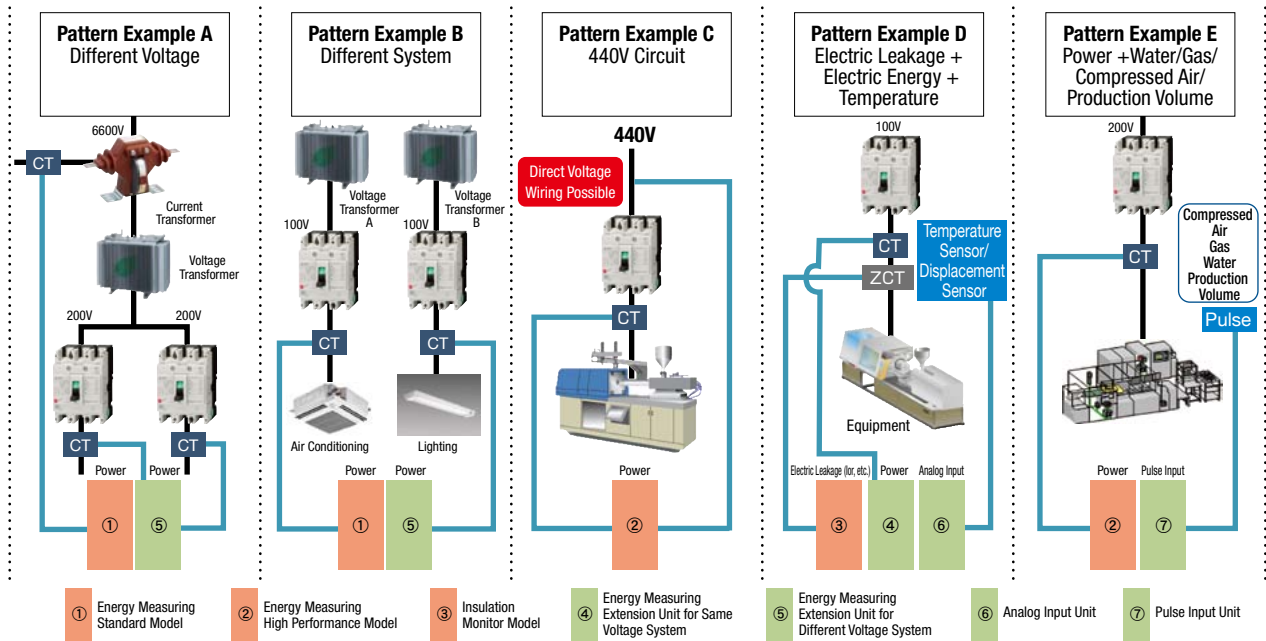

* These pattern examples show a schematic representation of one possible combination. Please be sure to check the wiring methods in the operation manual before using this equipment.

Free software can be used to ease the burden of creating reports

Measurement data is managed using a logging unit (SD memory card)

Using a logging unit combined with a Logging Unit Utility (free software), reports can be easily created based on the measurement data logged.

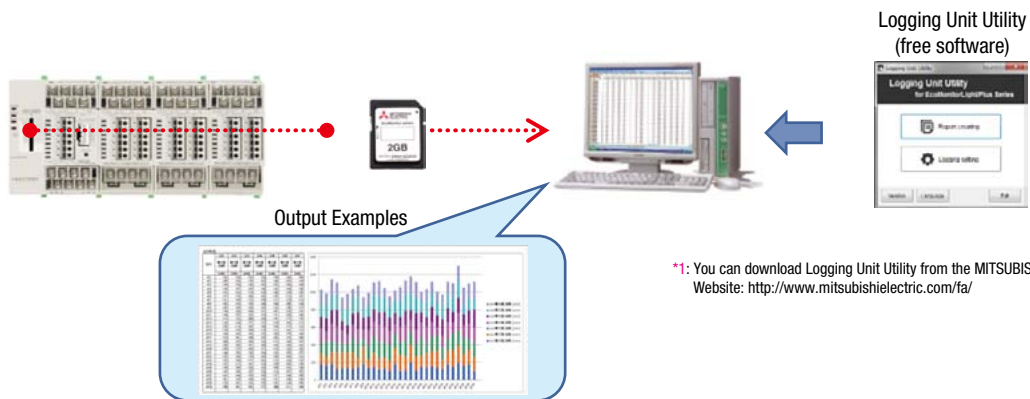

Utilize EcoWebServer III to visualize energy consumption while remote monitoring via a web browser

Utilize EcoWebServer III for centralized management when expanding measurement circuits!

System visualization with EcoWebServer III

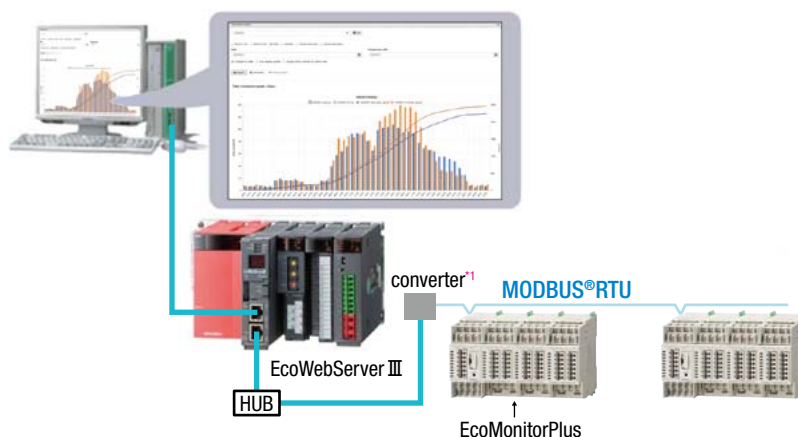

*1: MODBUS[®]TCP ↔ MODBUS[®]RTU converter is necessary.

Programmable Logic Controller MELSEC-Q Series Energy Measuring Module/Insulation Monitoring Module

Slots directly into MELSEC-Q PLC and enables easy measurement of a variety of energy-related information!

A PLC-installable measurement device that enhances productivity by reducing production equipment energy consumption and realizing preventive maintenance.

Simple Specifications Table

	Energy Measuring Module				Insulation Monitoring Module
Model name	QE81WH	QE84WH	QE81WH4W ^{*1}	QE83WH4W ^{*1}	QE82LG
Phase wire system	3-phase, 3-wire		3-phase, 4-wire		3-phase, 3-wire
Items measured	Electric energy (consumption, regenerative), reactive energy, current, voltage, power factor, frequency, etc.)				Leakage current Resistive-component leakage current
No. of measured circuits	1-circuit	4-circuit	1-circuit	3-circuit	2-circuit

^{*1}: A special-purpose voltage converter is required for QE81WH4W and QE83WH4W



Energy Measuring Module QE81WH Energy Measuring Module 3-phase, 4-wire QE81WH4W Energy Measuring Module Multi-circuit model QE84WH/QE83WH4W Insulation Monitoring Module QE82LG

1. Energy Measuring Module Features

1. Space-saving measuring device

- An energy measuring device can be added to an empty slot in the base unit without affecting the layout of devices in the control panel.

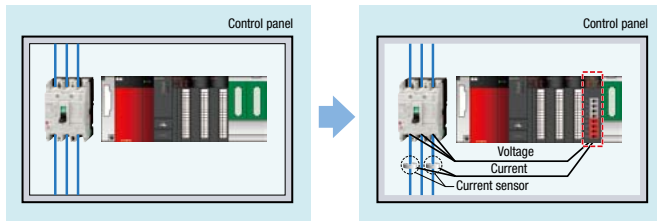

3. Management based on specific energy consumption possible by measuring energy of each piece of equipment

- Specific energy consumption^{*2} can be easily calculated by combining the production data of the CPU module with the energy data of the Energy Measuring Module. Measurement data is automatically collected at a speed of 250ms^{*3} and stored in the buffer memory, therefore enabling precise management of specific energy consumption.

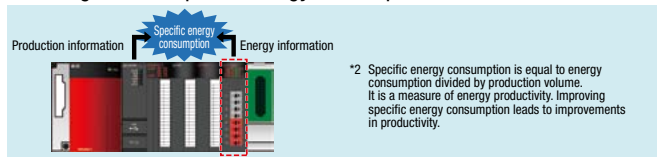

^{*2} Specific energy consumption is equal to energy consumption divided by production volume. It is a measure of energy productivity. Improving specific energy consumption leads to improvements in productivity.

^{*3}: QE84WH and QE83WH collect data in 500ms cycles

2. Reduced wiring and engineering set-up work

- Less wiring and engineering set-up work is required since the communication unit, cable and program are no longer required. As a result of the reduced workload, cost is also reduced.

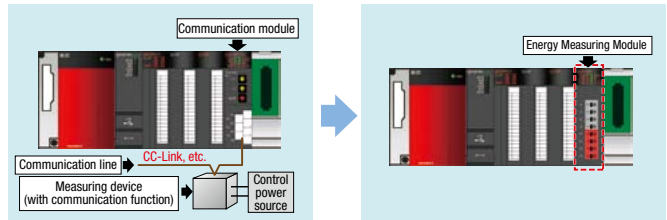

4. System construction enables simple visualization of energy consumption

- Visualization of specific energy consumption in the form of a graph is easily achieved by installing a graphic operation terminal (GOT) on the control panel onsite at the factory. Analysis is also possible using a computer combined with a high-speed data logger unit (QD81DL96).

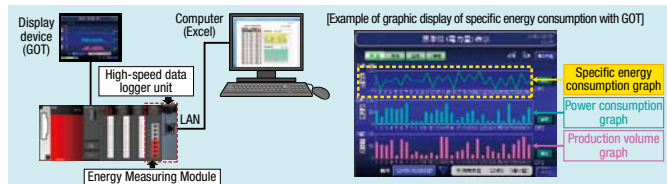

2. Multi-Circuit Model Current Measuring Mode (QE84WH, QE83WH4W)

- In the current measuring mode, up to eight circuits can be measured for current alone.^{*4} If only current is measured, a maximum of eight currents can be measured in a 100ms cycle. Modules with this mode are space-saving and provide the ideal solution for managing current values linked to production equipment.

Installation diagram

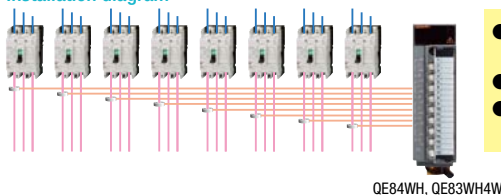

- Upper-/Lower-limit monitoring possible
- Measures up to eight circuits
- Data refreshed in 100ms cycles

Handy ways to use current measuring mode

- Electrical current abnormalities can be detected in a short measurement cycle, making it possible to determine product defects. (e.g., manufacturing lines of semiconductors, precision devices, LCD panels, etc.)
- Abnormal electrical current values can be detected and equipment status monitored. Equipment problems can be determined in advance.

^{*4}: Items other than the current cannot be measured in the current measuring mode.

3. Examples of Solutions through Installing an Energy Measuring Module

Solution Example 1

Specific energy consumption can be managed in detail according to individually manufactured products or processes. This helps to reduce the power consumption of production equipment and save energy.

Energy savings

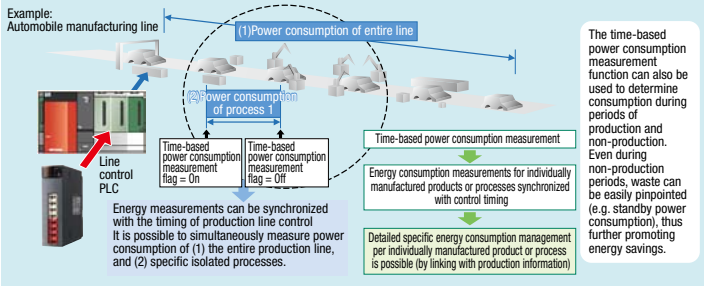

Solution Example 2

Constantly measuring power (or current) consumption can help prevent sudden faults and equipment failure, ultimately resulting in reduced production losses.

Example: An increase in power (or current) consumption is detected, therefore preventive measures to rectify the problem, such as refilling the lubricant or replacing the grinding machine (cutting blade), can be taken.

Preventive Maintenance

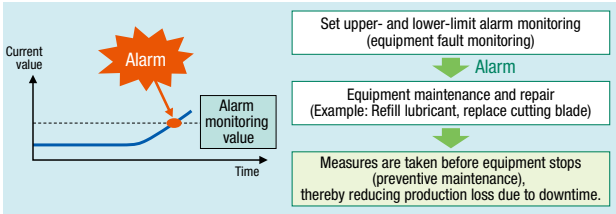

4. Insulation Monitoring Module Features

1. Early detection of insulation deterioration in production equipment!

- The module is connected directly to the PLC in the control panel, allowing leakage current from a location close to the load to be easily measured without the need for additional installation space.
- With its high-sensitivity mode, the module can detect leakage current in units of 0.01 mA, therefore it will not overlook insulation deterioration as it progresses in production equipment motors, etc.
- Upper-limit monitoring values for alarms can be set in two stages. Insulation deterioration/condition is assessed at an each stage, enabling countermeasures to be taken before a sudden equipment stoppage or malfunction.

With conventional insulation monitoring equipment, it was possible to identify the system where leakage was occurring, but it wasn't possible to pinpoint insulation deterioration in specific equipment.

The insulation monitoring module is able to quickly identify points where insulation is deteriorating in equipment.

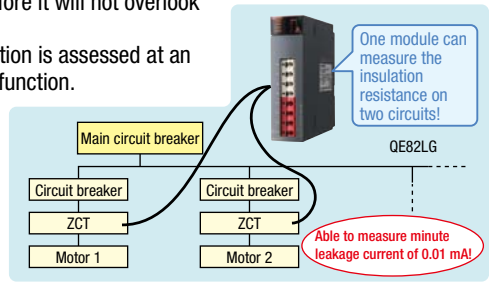

2. Constant monitoring for insulation deterioration in equipment using the Ior method!

- The module can measure resistive-component leakage current (Ior). Even in circuits that cannot be monitored for insulation using the conventional Io method, such as inverter circuits where capacitor component leakage current (Ioc) is large, the module removes the Ioc component to accurately monitor the leakage current caused by insulation deterioration.
- The module constantly measures the resistive-component leakage current (Ior) even while equipment is running. It detects any sign of insulation deterioration without interrupting power.

The Ior method adopted is that which is stated in the "Standard Specifications for Public Works Construction (Electric Equipment Work)" supervised by the Ministry of Land, Infrastructure, Transport and Tourism.

Since leakage current (Io) is affected by the Ioc of the entire facility, Ior measurement is effective for insulation deterioration diagnosis!

- Method of leakage current measurement (Io and Ior measurements)

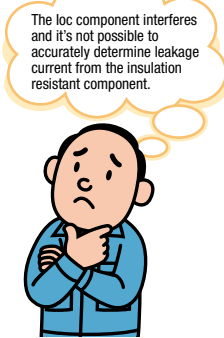
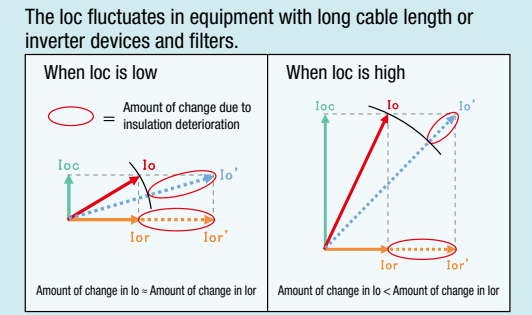
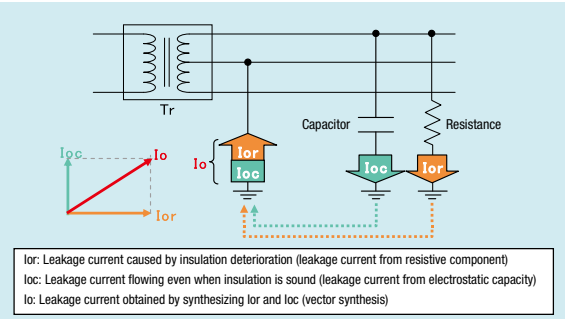

5. Example of a Solution by Installing an Insulation Monitoring Module

Constant measurement of leakage current (Io or Ior) can prevent sudden failures and reduce production loss due to equipment downtime.

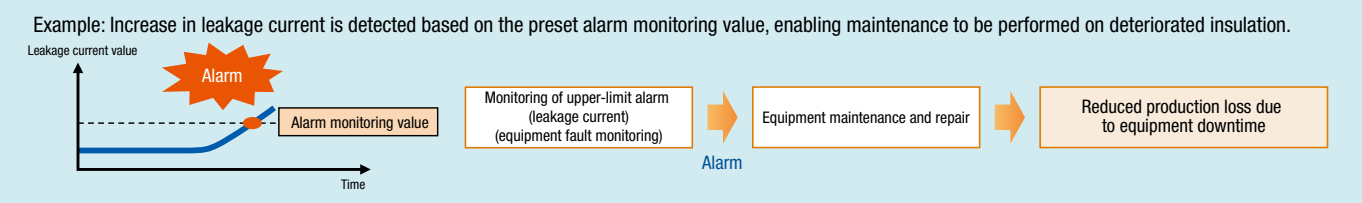

Electronic Multi-Measuring Instrument

Using the ME96SS Ver.A series, a single unit can replace nine devices (indicators and transducers), simplifying the system, improving performance, and reducing cost.



1. Line up

Model name	Transmission/Option specifications	Main items measured
ME96SSHA-MB (High-performance model)	MODBUS [®] RTU communication Plug-in module (options) <ul style="list-style-type: none"> Analog/Pulse/Contact output/input CC-Link communication Digital input/output (for MODBUS[®] RTU communication) Backup (on SD card) MODBUS[®] TCP communication 	A, DA, V, Hz = $\pm 0.1\%$ W, var, VA, PF = $\pm 0.2\%$ Wh = class 0.5S (IEC62053-22) varh = class 1S (IEC62053-24) Harmonics = 31 st -deg (max) Rolling demand = W, var, VA
ME96SSRA-MB (Standard model)	MODBUS [®] RTU communication Plug-in module (options) <ul style="list-style-type: none"> Analog/Pulse/Contact output/input CC-Link communication Digital input/output (for MODBUS[®] RTU communication) Backup (on SD card) MODBUS[®] TCP communication 	A, DA, V = $\pm 0.2\%$ Hz = $\pm 0.1\%$ W, var, VA, PF = $\pm 0.5\%$ Wh = class 0.5S (IEC62053-22) varh = class 1S (IEC62053-24) Harmonics = 19 th -deg (max) Rolling demand = W, var, VA
ME96SSEA-MB (Economy model)	MODBUS [®] RTU communication	A, DA, V = $\pm 0.5\%$ Hz = $\pm 0.2\%$ W, PF = $\pm 0.5\%$ Wh = class 0.5S (IEC62053-22) Harmonics = Only total

Optional Plug-in Modules

Model name	Analog output	Pulse/Alarm output	Contact input	Contact output	Transmission function	Used with
ME-4210-SS96	4	2	1	-	-	ME96SSHA-MB ME96SSRA-MB
ME-0040C-SS96	-	-	4	-	CC-Link	
ME-0052-SS96	-	-	5	2	-	
ME-0000BU-SS96	-	-	-	-	SD CARD	
ME-0000MT-SS96	-	-	-	-	MODBUS [®] TCP	

Note: Optional Plug-in Module can not be used with ME96SSEA-MB.

2. Features

1. Clear display

- Each item measured can be displayed by a bar graph. Using the bar graph display, one can grasp the rated value and percentage against the alarm value instantly.

Four characteristics displayed simultaneously

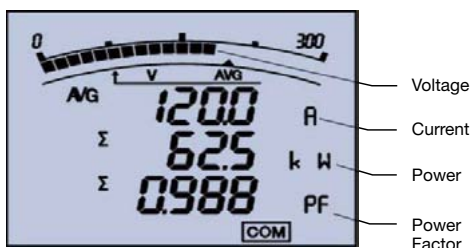

2. Advanced measuring functions

	High-performance model	Standard model	Economy model	
Model	ME96SSHA-MB	ME96SSRA-MB	ME96SSEA-MB	
Measurement items and accuracy	Active energy	Class0.5S	Class0.5S	
	Reactive energy	Class1S	Class1S	
	Power factor	$\pm 0.2\%$	$\pm 0.5\%$	$\pm 0.5\%$
	Harmonics	$\pm 1.0\%$ (Up to 31st)	$\pm 1.0\%$ (Up to 19th)	$\pm 2.0\%$ THD
	Demand	A (thermal), W, var, VA (rolling)	A (thermal), W, var, VA (rolling)	A (thermal)

Improved measurement functions

- ME96SSEA-MB(Economy model)
 - Active energy "Class1" measurement accuracy improved \rightarrow "Class0.5S"
 - "Total Harmonic(THD)" measurement function added
- ME96SSRA-MB(Standard model)
 - Active energy "Class1" measurement accuracy improved \rightarrow "Class0.5S"
 - Expand measurement range of Harmonic (Up to 13th \rightarrow "Up to 19th")
- ME96SSHA-MB(High-performance model)
 - "var/VA(rolling Demand)" measurement added

3. Additional functions

Use an optional Plug-in Modules, and add Analog/Pulse/Contact output, Contact input, CC-Link communication, MODBUS® TCP communication and Backup (on SD card) functions.

Data backup

- There is an optional module that can store data even when communication cannot be established.



Network

- ME96SS is equipped with the RS-485 communication function as standard. Other available optional modules include CC-Link communication and MODBUS® TCP communication for Ethernet network.

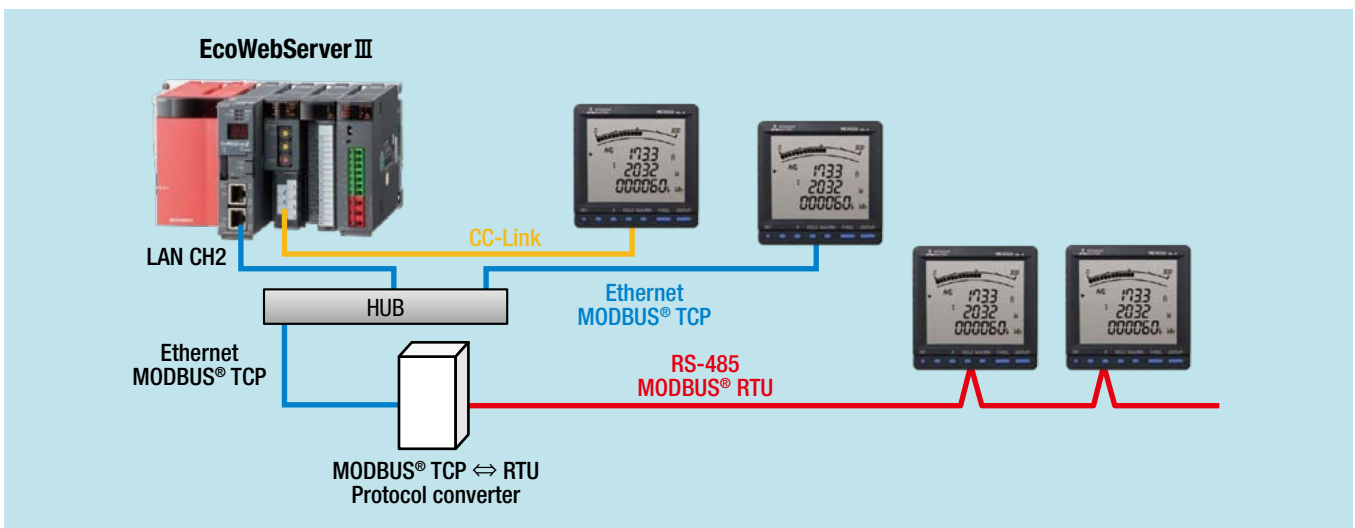

Remote I/O

Use the ME96SS Ver.A Series (SSRA/SSHA) to remotely interface with local devices such as ACBs. This allows users advanced control without having to deploy secondary control devices.

- Attachment of ME-0052-SS96 (optional) enables remote monitoring of the contact input signal and on/off control of the contact output signal.
- Digital input signals can be latched for over 30ms, and there is no need for external latch circuits.

ME96SS with Digital input and output unit[※](ME-0052-SS96) enables remote monitoring and on/off control with PLC!

Transfer the energy data and contact input/output signal via MODBUS®RTU

Another DI/DO terminal is not necessary.
⇒Space & Cost Saving

※Digital Input: Up to 5points, Digital Output: Up to 2points

【Control(contact output)】

- ➡ ON signal
- ➡ OFF signal

【Alarm/Status(contact input)】

- ← AL
- ← PAL
- ← TAL(only ACB)
- ← on/off status

MDU Circuit Breakers

Measuring display unit (MDU) circuit breakers are a combination of circuit breaker, measuring device and display that make it possible to also measure, display and transmit information about electric circuits. They support energy savings by requiring less space, less installation work and less wiring. The MDU circuit breakers of the WS-V Series are designed even more compact, with the LCD screen for displaying circuit information embedded on the front of the main unit.

An Abundance of Functions in a Compact Body! Energy-saving management support, requiring less space and less installation work!

Multifunctional electronic circuit breakers equipped with a measuring unit and display that measures electric circuit information and displays it in digital form. The lineup of MDU-equipped no-fuse circuit breakers offers a rating range from 125A to 800A to support detailed energy management and our customers' energy-saving activities.



1. Simple circuit measurement and monitoring supports various forms of energy-saving management

Precise energy management achieved by measuring and displaying the load current, line voltage, power, electric energy, harmonic current and power factor flowing through the circuit breaker.

Examples of MDU circuit breaker usage (monitoring power at transformer substations and on production lines)

Applications

Measuring power at assembly factories

- (1) Utilize initially to eliminate waste by understanding the relationship between production and power consumption
- (2) Use as a tool for visualized management, thereby supporting planning, confirmation, analysis and evaluation of energy-saving activities

Effects of Introduction

- (1) Automation of periodic measurements
 - Hourly automatic measurement is possible
 - Daily measurement through visual confirmation requires reading measurement values in multiple locations, recording the values and then entering them into a computer
- (2) Automation of detailed measurements
 - Using computer settings, it is possible to automatically measure electricity used by specific equipment (measure at 5-minute intervals for up to one week)

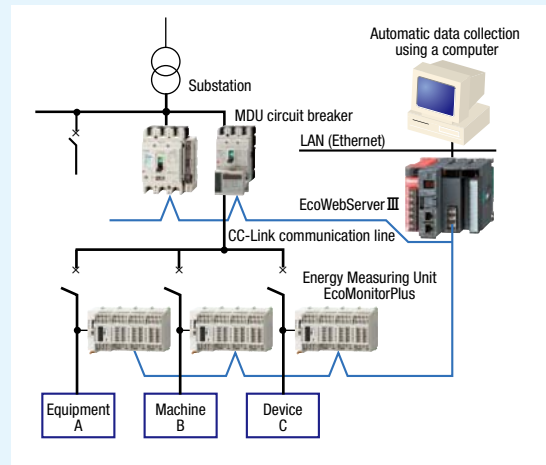

2. Less Wiring, Less Installation Work, Less Space

Less wiring, less installation work and less space achieved by integrating a VT/CT/MDU and a circuit breaker!

1. Less Wiring and Less Installation Work

- Measuring devices no longer require wiring, thereby reducing complicated wire connection work and installation.

Installation		Conventional device combination	Using MDU circuit breaker
Wiring	CT line	ammeter, wattmeter, power factor meter, harmonic current meter, current demand meter, electric energy meter, T/D (current, power, power factor, harmonic current, current demand)	Unnecessary
	Voltage line	voltmeter, wattmeter, power factor meter, electric energy meter, T/D (voltage, power, power factor)	Unnecessary
	Auxiliary power	T/D (current, voltage, power, power factor, harmonic current, current demand), transmission device	Necessary
	Measurement signal line	Transmission device input	Unnecessary
	Transmission line	Transmission device	Necessary
No. of devices installed		18	1
Installation/Connection check		Wiring/Device confirmation	Necessary, but easy

Example MDU installation

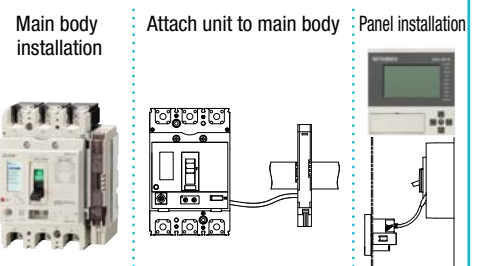

The MDU can be separated from the circuit breaker and a panel installed. The standard length of the connection cable for panel installation is 2m. (Connection cable lengths of 0.5m, 3m, 5m and 10m can also be used)

2. Saves Space

- When installing a new control panel, using a MDU circuit breaker makes it possible to reduce overall installation space.

3. Simple

- By incorporating a MDU circuit breaker when renewing control panels, space inside the panel can be utilized more effectively, while upgrading the panel with the addition of measuring and display functions using the same area as a conventional circuit breaker.

3. Highly Functional Diversified Features

1. Electric Circuit Monitoring

- By constantly monitoring the electrical current being used and generating a warning when pre-set values are exceeded, unnecessary breaker tripping can be avoided and a continuous power supply maintained. Moreover, various circuit-related alarms are generated via the LED display, which serves as an easy-to-use monitoring system.

Various Alarm Signals (WS-V Series)

Alarm	Description	LED display	Transmission	Contact output
AL (Alarm switch)	Circuit breaker trip state	No	Yes (option)	Yes (option)
AX (Auxiliary switch)	Circuit breaker ON/OFF state	No	Yes (option)	Yes (option)
PAL	Load current pre-alarm	Yes (option)	Yes (option)	Yes (option)
OVER	Overcurrent alarm	Yes	Yes	No
IDM-AL	Current demand alarm	Yes	Yes	No
ILA-AL	Current open-phase alarm	Yes	Yes	No
IUB-AL	Unbalanced current alarm	Yes	Yes	No
NLA	Neutral line open-phase alarm	Yes	No	No

* CC-Link communication is the transmission method.

* The PAL functions of LCD display, transmission and contact output are effective when a PAL module is attached (option).

Measuring Display Section

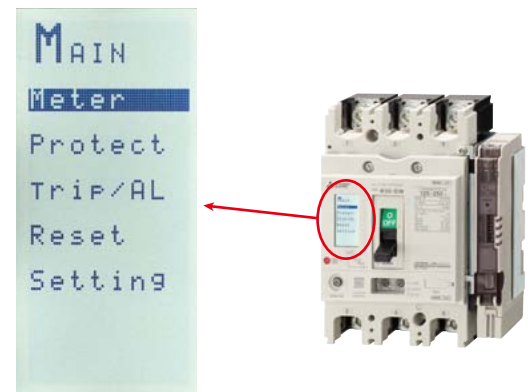

2. Preventive Maintenance

- When the circuit breaker trips, the reason for tripping and the electric current at that point in time are recorded in the MDU circuit breaker's non-volatile memory, thereby enabling the cause of trips to be quickly identified and enabling early recovery. Moreover, if CC-Link is used, the times when peak values occur are also recorded in the MDU circuit breaker non-volatile memory, which is helpful in assessing the peak times for electricity usage.

Items recorded in memory

Reason for tripping	Displays one of the following 250A frame: Overload/short circuit (AL) 400/630/800A frame: Overload (L), short circuit (SI) * Display flashes when circuit breaker trips.
Electric current at time of trip	Displays up to 16 times the maximum rated current for the current at the time of overload or short circuit (up to 10 times for 250A frame).
Maximum values recorded	Current demand value, voltage value, overall harmonic current demand value, power demand value, time-electric energy volume

Phase current display

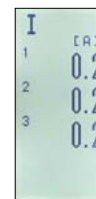

During alarm output



Measuring/Displaying

Applicable model	No-fuse circuit breaker			
	NF250-SEV with MDU NF250-HEV with MDU	NF400-SEP with MDU NF400-HEP with MDU	NF630-SEP with MDU NF630-HEP with MDU	NF800-SEP with MDU NF800-HEP with MDU
Load current of each phase: present value, demand value, maximum demand	○	○	○	○
Line voltage Present value, demand value, maximum demand	○	○	○	○
Harmonic current 3 rd , 5 th , 7 th , ..., 19 th , overall harmonic current, present value, maximum value, demand value, maximum demand	○	○	○	○
Power Present value, demand value, maximum demand	○	○	○	○
Electric energy	○	○	○	○
Power factor, Present value	○	○	○	○
External output	CC-Link communication, pulse output (electricity used)			

Energy Saving Data Collecting Server EcoWebServer III

EcoWebServer III simplifies the data analysis tasks necessary for saving energy. With simple settings, the EcoWebServer III can collect measurement data from measurement devices connected to the field network (MODBUS or CC-Link), convert the data into graphs using a web browser and display it as current values.



Model MES3-255C-EN



Model MES3-255C-DM-EN

Overview of EcoWebServer III

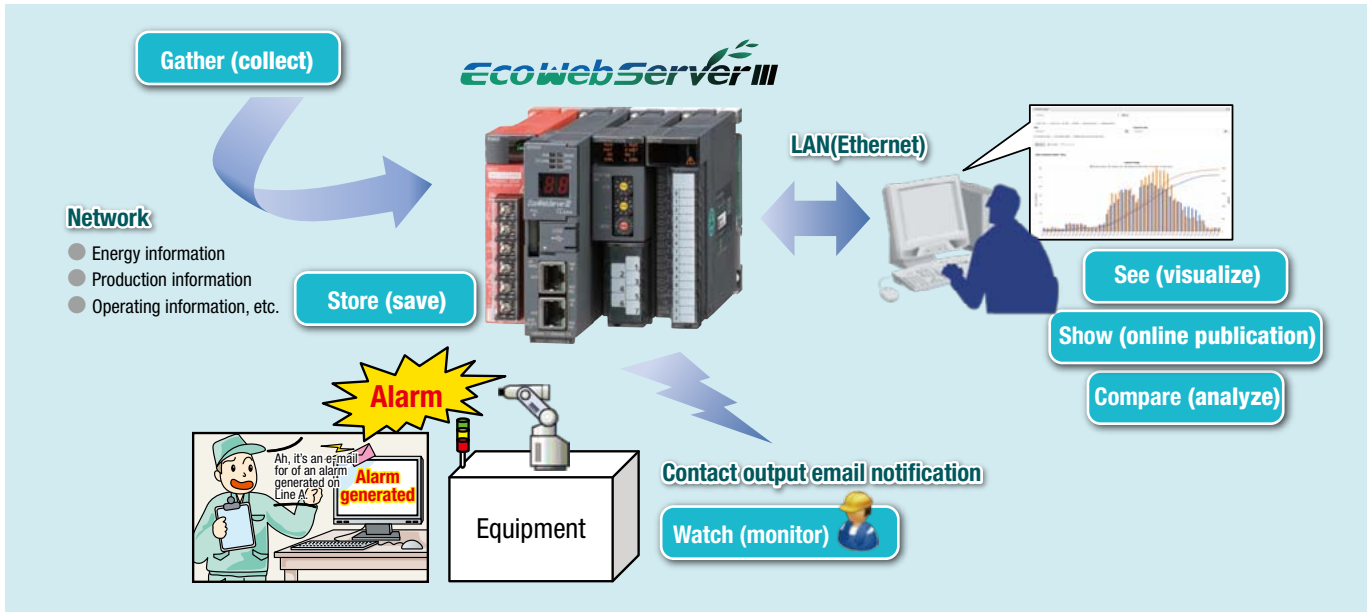

1. No need to add programs or software

- Measurement data can be displayed as graphs on the web browser.
- Possible to confirm energy consumption status in detail, using consumption by the minute (measurement value).

Simple settings

- Measurement possible using (1) Measuring terminal registration → (2) Measuring point registration → (3) Grouping registration → (4) Project writing.

(1) Register device information

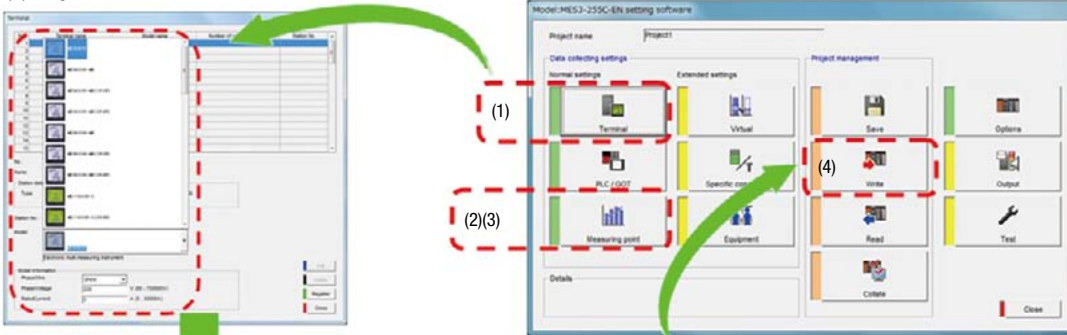

(2) Select data from list



(3) Group

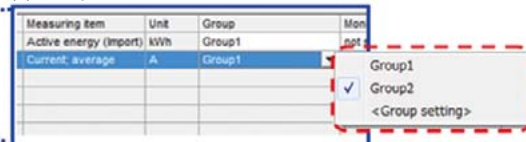

2. Easily understand productivity by confirming the specific consumption graph

- By integrating the production volumes from the measuring terminal and PLC, the specific consumption graph can be easily displayed and points related to the drop in specific consumption can be easily understood.
- Additionally, by comparing two specific consumption graphs at the same line, it is possible to confirm the benefits at the time the countermeasure was implemented.

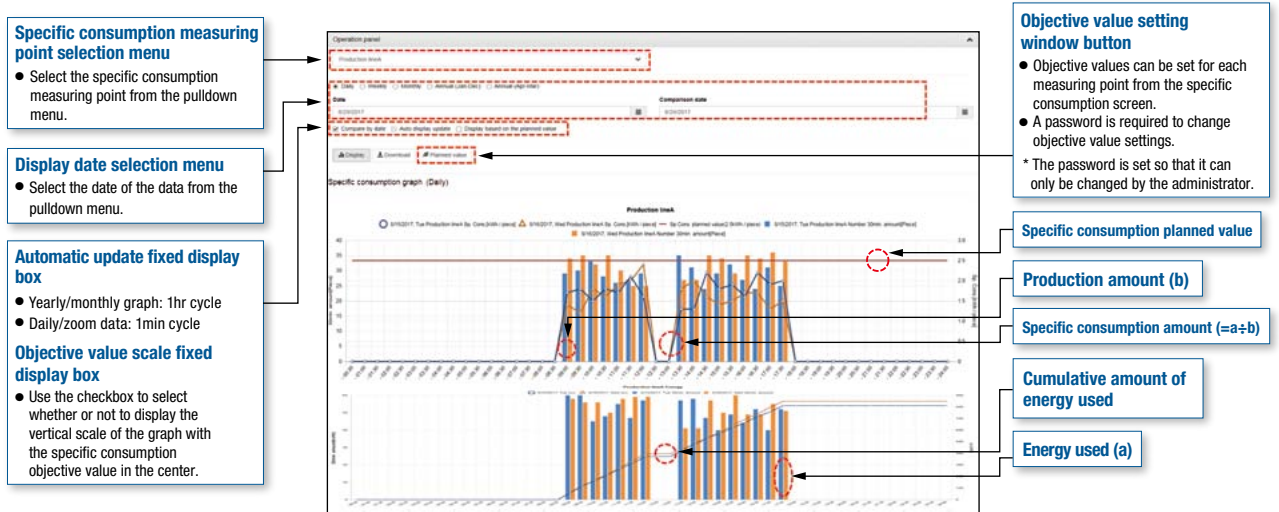

3. Connection with Mitsubishi Electric GOT display device

- Information collected on the EcoWebServer III can be displayed on the GOT.
- By displaying the alarm state/measuring value for energy information/demand, real-time monitoring at the site and urgent countermeasures are possible.

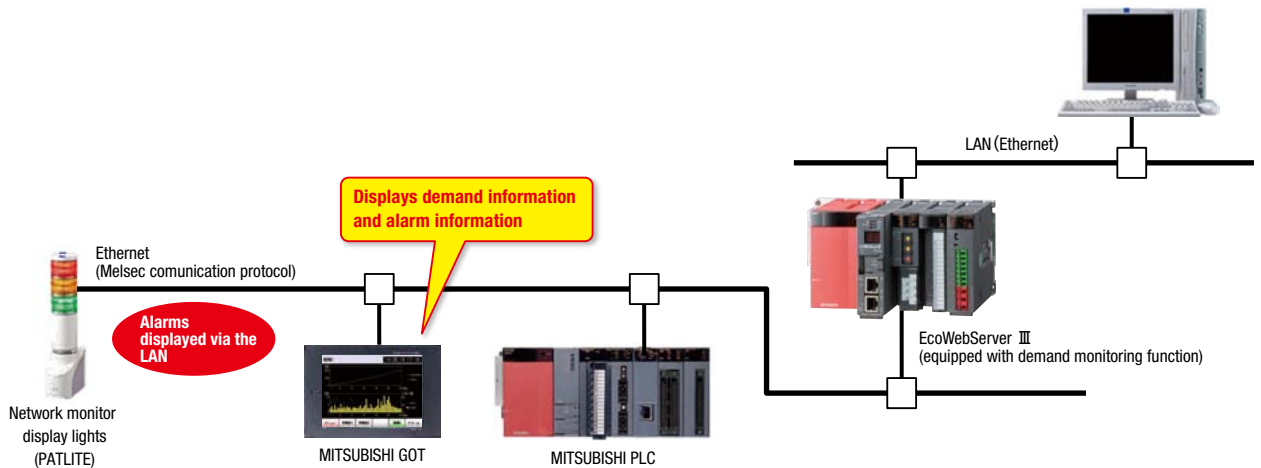

4. Alarm output/email notification through a variety of monitoring functions

- Objective values (upper/lower) and error information can be transmitted through email notifications/alarm output, and changes in status can be recognized immediately. The result of the careful target value management and monitoring the status monitoring ensure that problems occurring at the site are not overlooked.

<Items monitored>

- Energy plan value
- Specific consumption objective value
- Upper/lower irregularity
- Change in operating state
- Error information
- Demand alarm

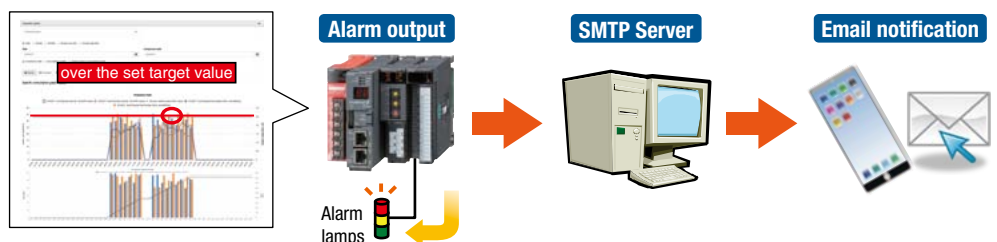

5. Monitoring Notification Function Enhancement

- Automatic transfer, email notification and contact output is possible for data collected.
- Notifications when energy exceeds planned consumption value and specific consumption target values are provided in the form of alarms or emails.

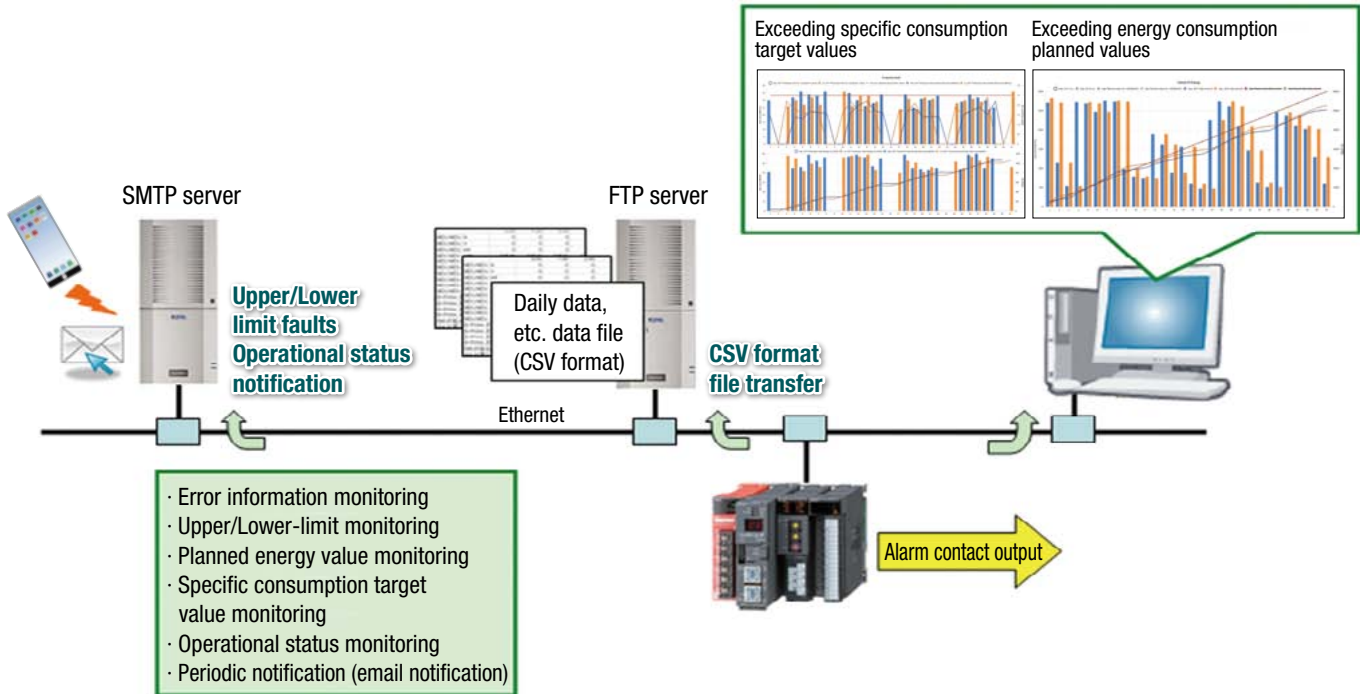

Energy Saving Data Collecting Server EcoWebServer III

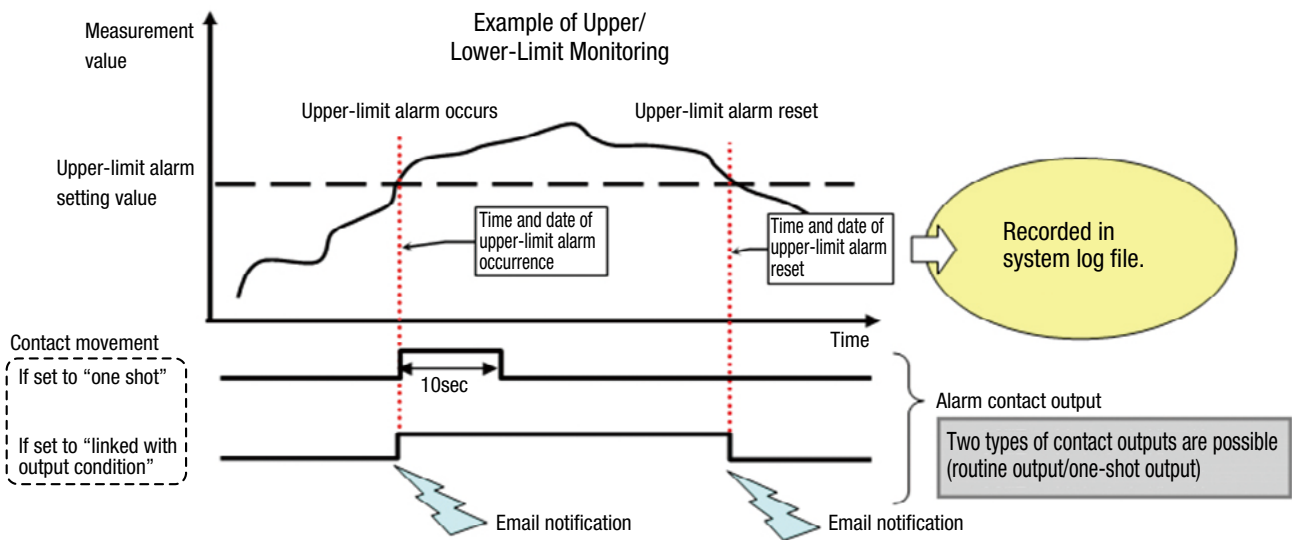

- Contact status can also be confirmed using web browser and be turned off.

Contact output Monitor
2014/09/01 15:29:47

No.	Name	Item name	Destination	Ch	Output type	State	Control
1	Demand alarm level1	Level 1 alarm	Output unit	0	Interlock	OFF	OFF
2	Demand alarm level2	Level 2 alarm	Output unit	1	Interlock	OFF	OFF
3	Demand fixed alarm	Limit/Fixed alarm	Output unit	2	Interlock	OFF	OFF
4						OFF	OFF
5	Measuring error	Measuring error	Output unit	4	Interlock	ON	OFF

Alarms can be reset via the web browser

MES3-255C-EN example

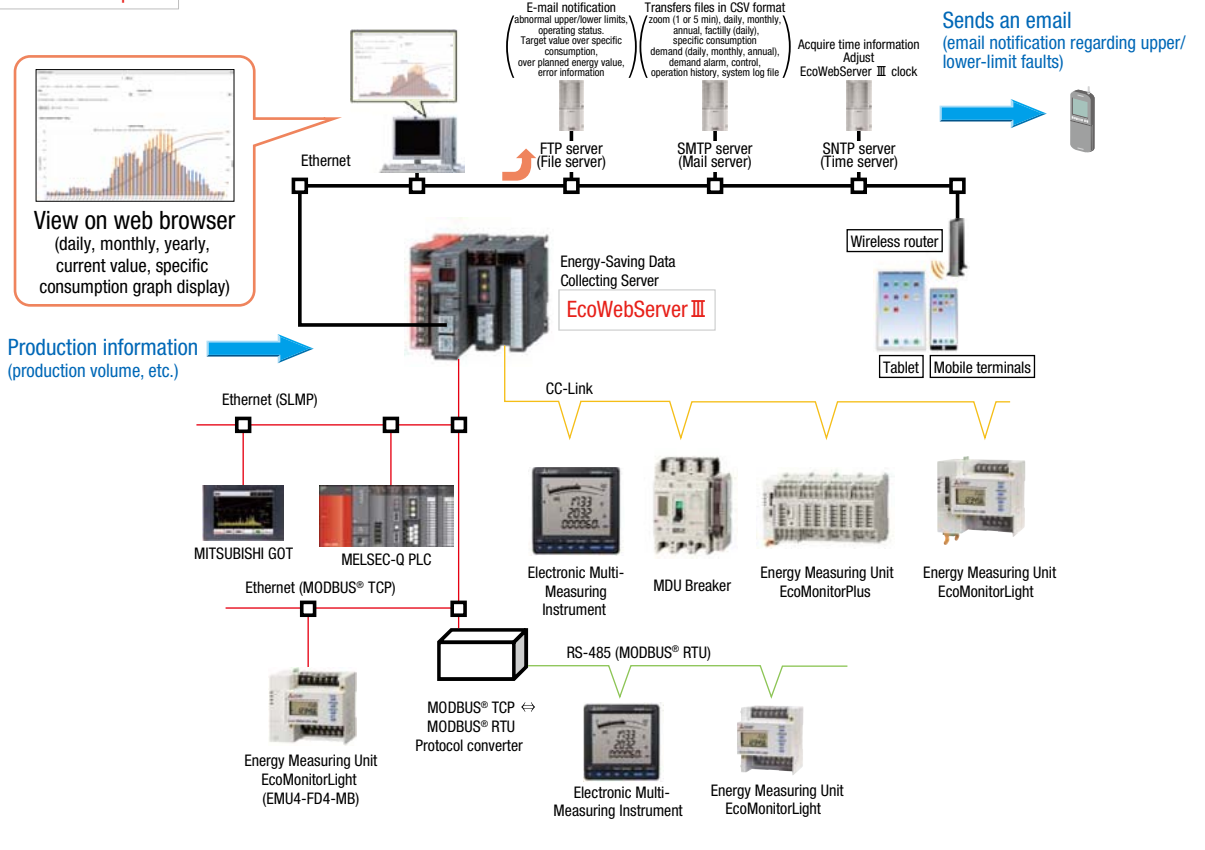

MES3-255C-DM-EN example

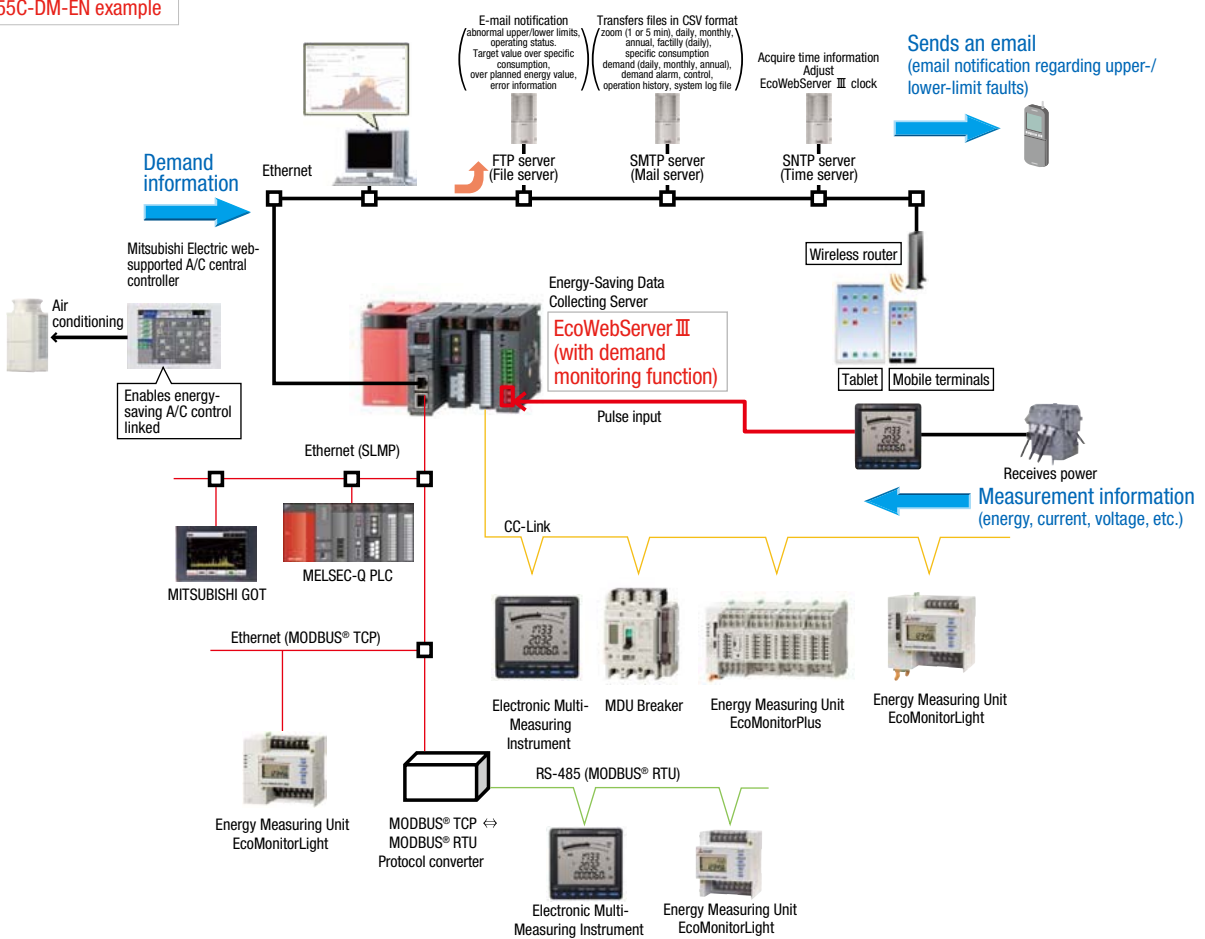

Example of Energy Monitoring System

Energy management of whole factory

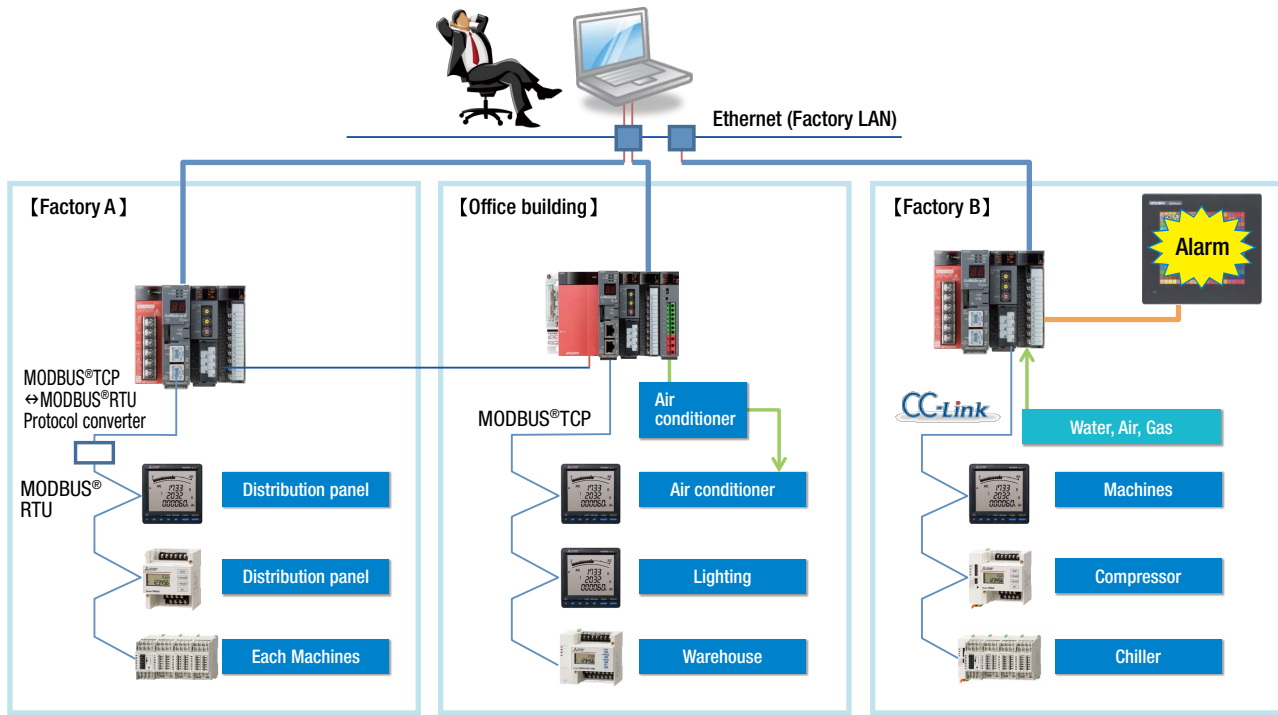

It is possible to monitor and understand energy consumption in each factory, including water, gas and air. Also, they have installed GOT in the electric room and monitored alarm status.

1. Example Use of office building

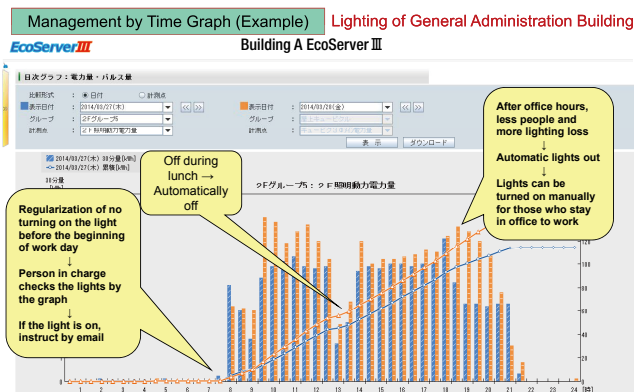

2. Example Use of Utility Management

Detect industrial water leakage from graph created by EcoWebServer III, preventing additional loss

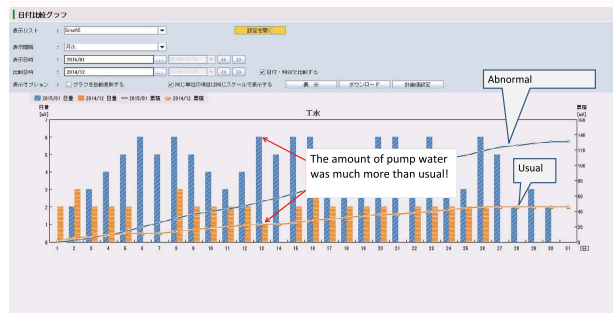

3. Example Use of specific consumption management

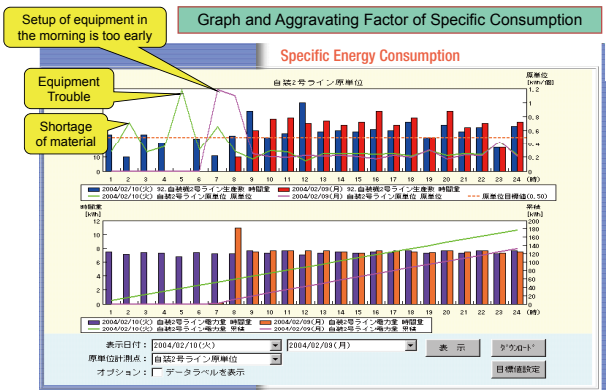

$$\text{Amount of Energy Consumed} \div \text{Production Quantity} = \text{Formula for Specific Energy Consumption}$$

Analyzing the specific consumption by time ⇒ The real culprit can be determined

Simple energy monitoring

Problem

- I do not understand how much electricity each facility uses in factory.
- I do not understand energy-saving efficiency when replacing equipment.
- However, I cannot invest much for energy-saving initiatives.



Solution!

- Electric energy of each device can be measured by installing one EMU4.

Non-ferrous metal manufacturer

- Measuring point : Facility in factory
- Customer's requests:
I want to do simple measurement to watch the actual condition closely.
I want to manage data by using SD card.

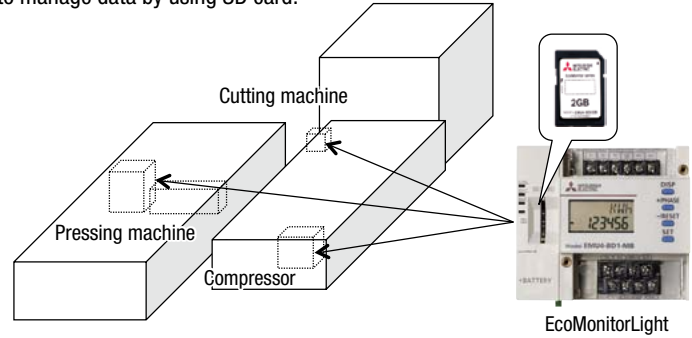

Introduction schedule

Status

1. **Measuring devices using one EMU4**
Measure each facility for a certain period of time to check power consumption
- ↓
2. **Introduce EMU4 for each facility**
Measure at all time to implement energy-saving countermeasures for measured value
- ⋮
3. Step up to visualization of entire factory

Introduction point

1. Enable to data collected off-line to be saved to SD card using Logging module.
2. Enable confirm energy-saving effect by comparing old and new performance when each device at factory is renewed. (Easy construction by segmented CT.)
3. System can be built gradually.

Preventive maintenance

Problem

- What is the best way to monitor equipment insulation using Inverter or servo motors...



Solution!

- Insulation deterioration is constantly monitored with the Insulation Monitoring Module.

Car/ Car parts manufacturer

■ Facility : Brazing furnaces with Inverter

- Application : Monitoring Insulation of brazing furnaces with inverter (heater)

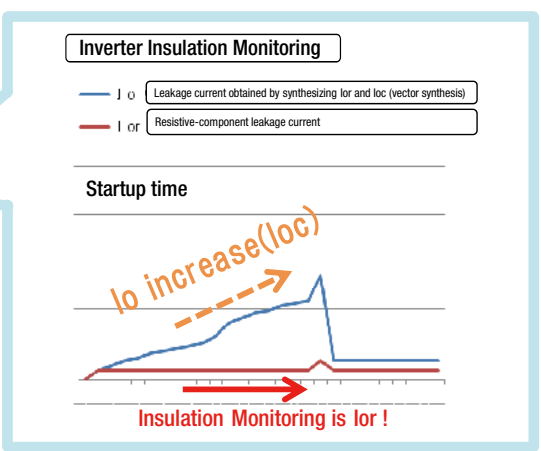
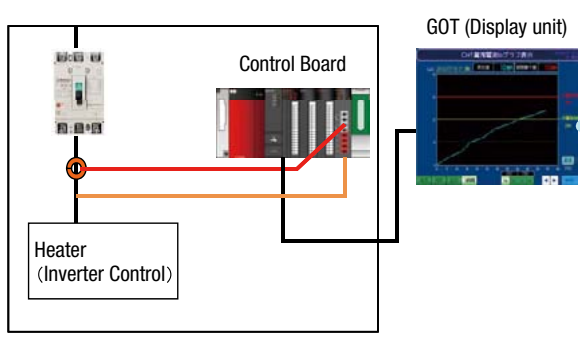

Points of introducing of QE82LG

Leakage current (I_{oc}) flows continuously in aluminum electrolytic capacitor used in Inverter or servo when machine is being turned on. Only with leakage current (I_o) is not enough to monitor Insulation correctly.

Measurement of Insulation deterioration can prevent sudden trouble and reduce production loss due to equipment stoppage by monitoring resistive-component leakage current (I_{or}).

Extruder with Inverter
is also enabled

- [Industry applications]
- Plastic products manufacturing
 - Rubber products manufacturing
 - Film products manufacturing

e-F@ctory SCADA Software - Create advanced integrated monitoring systems for automated equipment



MC Works64 is a one-stop solution for configuring highly functional monitoring control systems capable of incorporating Programmable Logic Controllers (PLCs), PCs and various FA equipments.

The Next Generation in Automation Software
MC Works⁶⁴

Save energy and reduce cost facility-wide while improving production and operation efficiency

- By monitoring energy consumption, energy use can be reduced over time. Use Mitsubishi Electric energy measuring modules together with AX Energy—optional dedicated energy management software for MC Works64—to optimize the visualization of energy consumption. AX Energy offers browser independent, real-time energy monitoring and management capabilities to address any application, from single buildings to multi-site locations and entire complexes. Site managers, building engineers or maintenance personnel can quickly and intuitively navigate to find opportunities for improving energy efficiency.



Expansive wide-area monitoring

- Use various Internet mapping applications, such as Bing, to easily obtain and display geographic information related to wide-area monitoring systems; doing so at no extra cost. Monitor business offices and factories located around the world and use pins to display detailed information and alarm status all on a single map. GPS data can also be monitored.

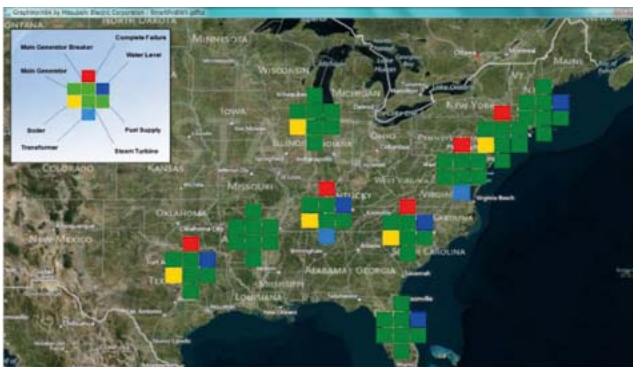

High reliability with redundant systems

- MC Work64 can be used to configure redundant server systems and server-client systems, enhancing system reliability at the time of a malfunction or disaster. Configure two servers (control server and standby server) to the required system size, from stand-alone to large-scale. Redundant systems for PLCs that control things like pumps, lighting and air-conditioning can be configured as well.

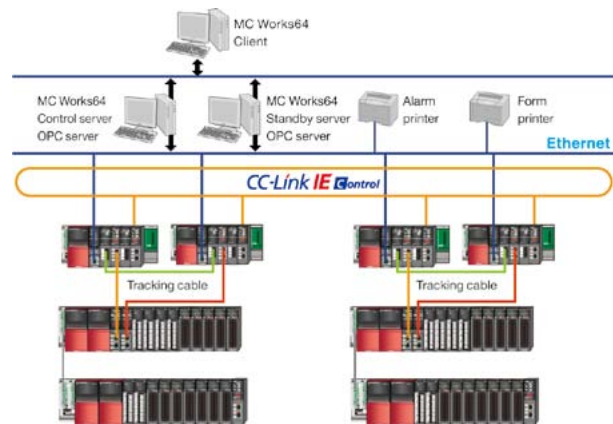

Remote monitoring from mobile devices

- MC Works64 has a mobile terminal application that enables building and factory operations to be monitored from outside the facilities. Access and monitor important data from remote terminals, even a smart phone, whenever required. Managers, engineers, operators and maintenance staff can access and monitor various data according to authority level; and view information about alarms, trends, energy use, quality and production in real time.



System management using operating schedule

- Use this built-in support tool to control factory operating schedules. Create and set commands to manage daily, weekly and monthly schedules as required. Intuitive setup is easy using an Outlook®-style template.

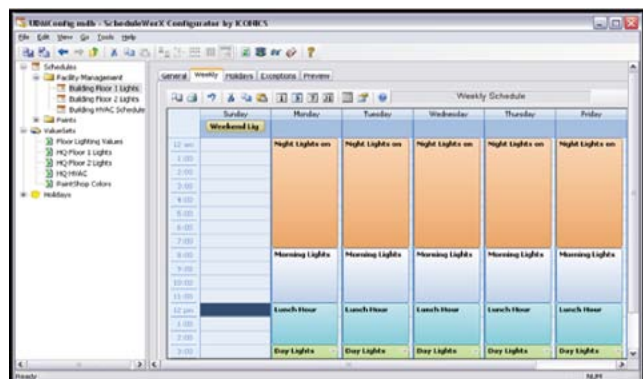

Reducing engineering cost by Customizable symbol library.

- A library with pre-made symbols comes as a standard feature, reducing the time required to create graphics. Custom symbols can also be created and imported into the library. The library comes stocked with more than 1,000 high-definition 2D and 3D symbols covering a variety of industries including water treatment, building management, food, chemicals, and more. There is also an animation function and symbols can be tagged to change colors and display numbers, thereby reducing the labor for creating script.

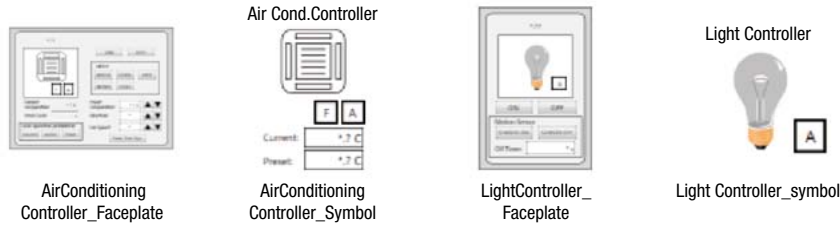

Factory Energy Management

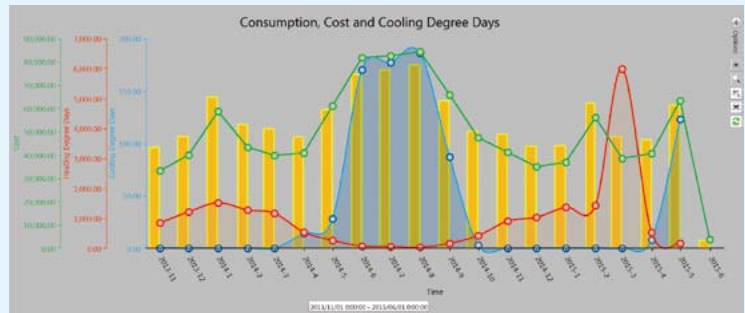

In addition to increasing factory production line efficiency, MC Works64 can control the temperature and airflow via centralized air-conditioning systems, and display the temperature and humidity, which are measured by sensors in each room. It can also monitor and analyze the operations of production machinery that consume large amounts of energy, and thus optimize production cost. Simply add the AX Energy software and Mitsubishi Electric energy measuring modules to create an energy-saving solution capable of advanced energy visualization, analysis and savings. A full lineup of energy-saving devices, such as Mitsubishi Electric inverters with superior motor-drive efficiency, are available to help realize greater energy savings from factory equipment.

Building Energy Management

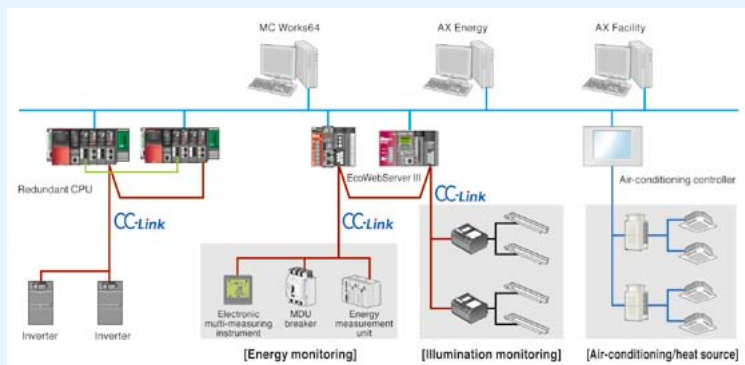

Used with EcoWebServer III and energy measuring modules, MC Works64 visualizes the energy used by systems throughout a building such as air-conditioning, lighting and gas and water supply. Combined with the optional visualization and diagnostics software AX Energy, energy consumption can be analyzed, points of waste documented and additional energy-saving measures introduced. MC Works64 also contributes to maintaining a comfortable indoor space by automatically switching between cooling and heating according to preset temperature and air-volume settings. Since air-conditioning systems consume a lot of energy—often more than 50% of the total energy used by a building—comfort can be sacrificed when pursuing energy savings. However, MC Works64 delivers energy savings while maintaining comfort through centrally managed air-conditioning control. Lighting system control is possible as well, such as scheduling ON/OFF times and using sensors to detect when people are present.

Enhanced Next-Generation Energy-Saving Inverter

F800

- Energy saving
- Functions ideal for fans and pumps
- Security & safety
- Compatibility with the environment
- Easy setup & operation



1. Energy Saving with Inverters

The consumed power of a variable-torque load, such as fans, pumps, and blowers, is proportional to the cube of its rotation speed. Adjusting the air volume by the inverter rotation speed control can lead to energy savings.

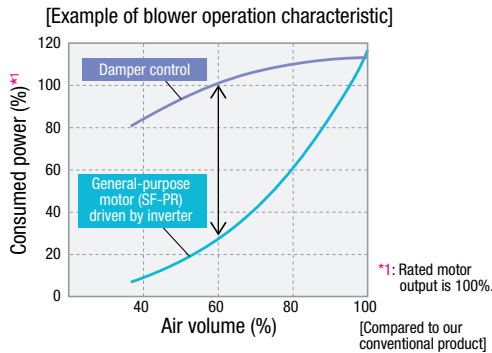

Utilizing the motor capability to the full

Optimum excitation control

- Optimum excitation control continuously adjusts the excitation current to an optimum level to provide the highest motor efficiency. With a small load torque, a substantial energy saving can be achieved. For example, at 4% motor load torque for a general-purpose motor, the motor efficiency under Optimum excitation control is about 30% higher than the motor efficiency under V/F control.

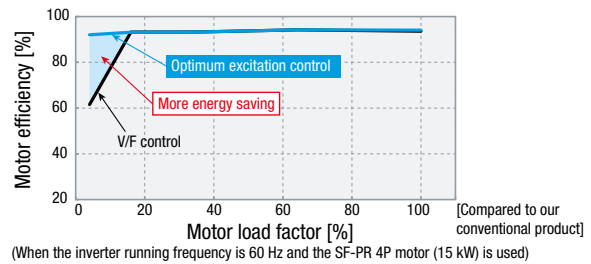

2. FUNCTIONS IDEAL FOR FANS AND PUMPS

System cost reduction

PID multiple loops (two loops)

Two PID operation units are available in the inverter. The inverter can perform PID control of the motor operation and control the external equipment at the same time. The system cost can be reduced because no external PID controller is required for controlling the external equipment.

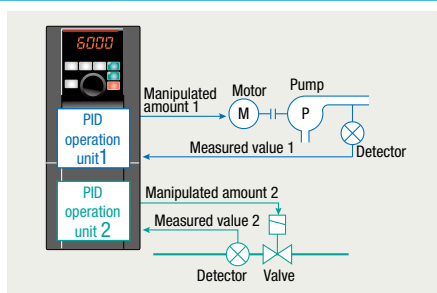

Cleaning of fans and pumps

Cleaning function

Foreign matter on the impellers or fans of pumps can be removed by repeating forward/reverse rotation and stopping of the motor. (Use this function when a back flush does not pose a problem.) This function can be also automatically started when the result of load characteristics measurement is out of range (overload).

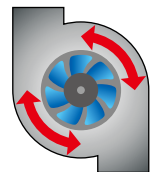

Model

FR - F 8 2 0 - 0.75K - 1

Symbol	Voltage class	Symbol	Structure, functionality	Symbol	Description	Symbol	Type	Symbol	Circuit board coating (IEC60721-3-3 3C2/3S2 compatible)	Plated conductor
2	200 V class	0	Standard model ^{*2}	0.75K	LD rated inverter capacity (kW)	-1	FM	None	Without	Without
4	400 V class	2	Separated converter type ^{*3}	00023	SLD rated inverter current (A)	-2	CA ^{*1}	-60	With	Without
								-06 ^{*4}	With	With

Inverter model	Inverter capacity
FR-F820	0.75 kW to 110 kW
FR-F840	0.75 kW to 315 kW
FR-F842	355 kW to 560 kW

*1: For the CA-type, the monitor output terminal FM/CA operates as terminal CA (analog current output 0 to 20 mA DC), not as terminal FM (pulse train output).
 *2: For the 75K or higher inverter, always connect a DC reactor (FR-HEL), which is available as an option. Select a DC reactor according to the applied motor capacity.
 *3: Always install the converter unit (FR-CC2). (Not required when a high power factor converter (FR-HC2) is used)
 *4: Available for the 7.5K or higher.

YOUR SOLUTION PARTNER

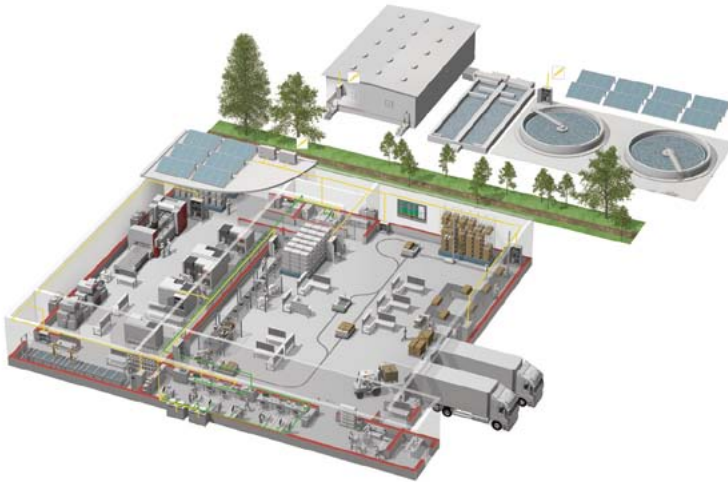

Mitsubishi Electric offers a wide range of automation equipment from PLCs and HMIs to CNC and EDM machines.

A NAME TO TRUST

Since its beginnings in 1870, some 45 companies use the Mitsubishi name, covering a spectrum of finance, commerce and industry.

The Mitsubishi brand name is recognized around the world as a symbol of premium quality.

Mitsubishi Electric Corporation is active in space development, transportation, semi-conductors, energy systems, communications and information processing, audio visual equipment and home electronics, building and energy management and automation systems, and has 237 factories and laboratories worldwide in over 121 countries.

This is why you can rely on Mitsubishi Electric automation solution - because we know first hand about the need for reliable, efficient, easy-to-use automation and control in our own factories.

As one of the world's leading companies with a global turnover of over 4 trillion Yen (over \$40 billion), employing over 100,000 people, Mitsubishi Electric has the resource and the commitment to deliver the ultimate in service and support as well as the best products.



Low voltage: MCCB, MCB, ACB



Medium voltage: VCB, VCC



Power monitoring, energy management



Compact and Modular Controllers



Inverters, Servos and Motors



Visualisation: HMIs



Numerical Control (NC)



Robots: SCARA, Articulated arm



Processing machines: EDM, Lasers, IDS



Transformers, Air conditioning, Photovoltaic systems

* Not all products are available in all countries.

Global Partner. Local Friend.

Precautions Before Use

- Please consult with a Mitsubishi Electric representative when considering the application of products presented in this catalogue with machinery or systems designed for specialized use such as nuclear power, electrical power, aerospace/outer space, medical, or passenger transportation vehicles.
- Mitsubishi Electric Corporation shall not be liable, to the customer or equipment user, for:
 - 1) Any damage found not to be attributable to a Mitsubishi Electric product.
 - 2) The loss of opportunity or profits for the customer or user caused by any fault in a Mitsubishi Electric product.
 - 3) Damage, secondary damage or accident compensation resulting from special factors regardless of whether or not such factors could be predicted by Mitsubishi Electric.
 - 4) Damage to products of other companies and/or guarantees relating to other services.

For Safety : Please read the instruction manual carefully before using the products in this catalog.
Wiring and connection must be done by the person who has specialized knowledge of electric construction and wirings.

●Trademarks

- Of this product, export (or service trade) permission under this law is required for exports that fall under the safety and trade control related cargo (or service) specified in the Foreign Exchange and Foreign Trade Control Law.
- Windows® is registered trademark in the U.S. of U.S. Microsoft Corporation, and other countries.
- MODBUS® is a registered trademark of Schneider USA Inc.
- Other company names and product names in this document are trademarks or registered trademarks of their respective owners.



for a greener tomorrow

Eco Changes is the Mitsubishi Electric Group's environmental statement, and expresses the Group's stance on environmental management. Through a wide range of businesses, we are helping contribute to the realization of a sustainable society.



MITSUBISHI ELECTRIC CORPORATION

HEAD OFFICE: TOKYO BLDG., 2-7-3 MARUNOUCHI,
CHIYODA-KU, TOKYO 100-8310, JAPAN