

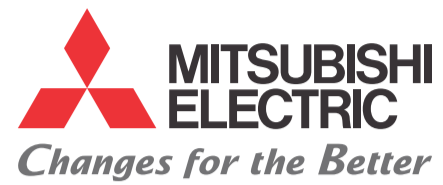

for a greener tomorrow



# SMART LOW VOLTAGE SWITCHGEAR SOLUTIONS



**Intelligent, Safe, Efficient & Reliable**

# AIR CIRCUIT BREAKERS



- GLOBAL
- BEST SOLUTION
- HIGH PERFORMANCE
- HIGH RELIABILITY
- USER FRIENDLY

### Available Frame Size

**Product Range**  
630-6300A  
**Rated Insulation Voltage**  
1000 V AC  
**Number of Poles**  
3.4  
**Rated Operational Voltage**  
690 V AC  
**Available Types**  
Drawout type, Fixed type  
**Network Links\***  
Profibus/DP, CC-Link, MODBUS

### Product Special Features

- Standard Pre Trip Alarm
- Fully Modular and Scalable Electronic Trip Unit
- Colour Changing Display to acknowledge faults and alarm
- Temperature Alarm
- Records last 10 Trips and 10 Alarms
- LED to indicate % Current Loading
- Fault Differentiating LED for OC, SC, EF & EL

### Higher short circuit protection performance by high breaking capacity

In Case of 690V AC, Icu = Ics  
65 kA for AE630-SW-AE2000-SWA  
75 kA for AE2000-SW-AE4000-SWA  
85 kA for AE4000-SW-AE6300-SW

### Wide coordination range by High rated short-time withstand current Icw (1s)

65 kA for AE630-SW-AE2000-SWA  
75 kA for AE2000-SW-AE4000-SWA  
100kA for AE4000-SW-AE6300-SW

**Icu=Ics (Rated Breaking Capacity)**

<b>65kA</b> <small>(AE630-SW-AE200-SWA)</small>	<b>75kA</b> <small>(AE2000-SW-AE4000-SWA)</small>	<b>85kA</b> <small>AE4000-SW-AE6900-SW)</small>
--	--	--

**Icw (1s) (Rated short-time withstand current)**

<b>75 kA</b> <small>(AE2000-SW-AE4000-SWA)</small>	<b>100 kA</b> <small>(AE4000-SW-AE6300-SW)</small>
---	---

### ELECTRONIC TRIP RELAY (ETR)

#### Main Setting Module

With interchangeable & add-on modules

WS1 WS2 WS3	General use	WM1 WM2 WM3	Generator protection use	WB1 WB2 WB3	Special use
LTD+STD+INST / MCR		LTD+STD+INST / MCR		INST / MCR	

#### Optional Setting Module

With optional setting modules, GFR, ER etc are added easily.

G1	E1	AP	N5
Ground fault protection (GFR)	Earth leakage (ER) <sup>(1)</sup>	2nd Additional Pre-alarm	Neutral pole <sup>(2)</sup> 50% protection

### Temperature Alarm (TAL)

When TAL sensor is installed in the breaker, temperature alarm is operative. When the temperature of main contact exceeds normal level, temperature alarm is indicated by LED on main setting module and also the output contact is made energize if power supply with output contact is installed. It is possible to know temperature rise caused by wear of main contact because TAL sensor is installed near main contact. When the temperature of main contact goes down to the normal level, temperature alarm turns off automatically.

### Network

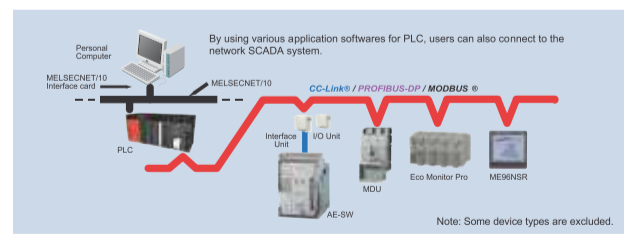

# MOULDED-CASE CIRCUIT BREAKERS



- GLOBAL
- INTELLIGENT
- STANDARDISATION
- HIGH QUALITY
- HIGH PERFORMANCE

**Product Range WS-V/W**  
 3-1600 A  
**Rated Insulation Voltage**  
 500-690 V AC  
**Rated operation Voltage**  
 up to 690 V AC, 500 V DC  
**Number of Poles**  
 2, 3, 4  
**Tripping Mechanism**  
 Thermal Magnetic, Electronic  
**Network Links\***  
 CC-Link®, Modbus  
**Special Type**  
 Earth Leakage and Motor Duty  
**Version**  
 Motorized and Plug-in



## High-level flexibility

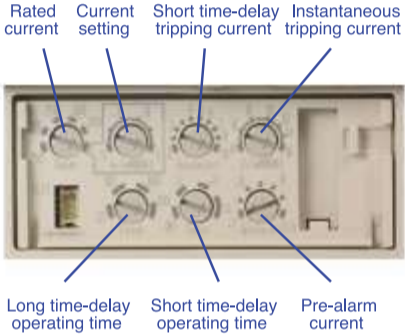

The electronic trip relay for 400-630 Amp provides high-level flexibility according to your demands

## Shunt-less Current Flow Technology

The constructive design of movable and fixed conductors considerably contributes to an increased life.

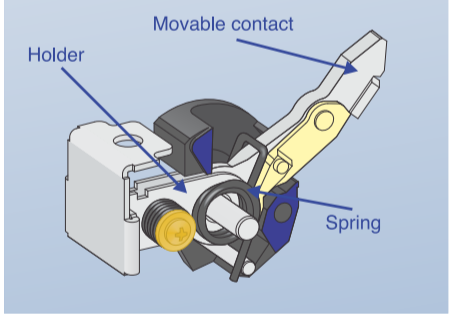

Constructive design for an increased life

## Expanded ISTAC - The Patented Trip Technology

The new circuit breaking technology "Expanded ISTAC" has improved the current-limiting performance and upgraded the overall breaking capacity. Expansion of the conductor under the stator shortens the contact parting time of the mover as compared to the conventional ISTAC structure. The current-limiting performance has been improved remarkably. (The maximum peak current value has been reduced by approx. 10%.)

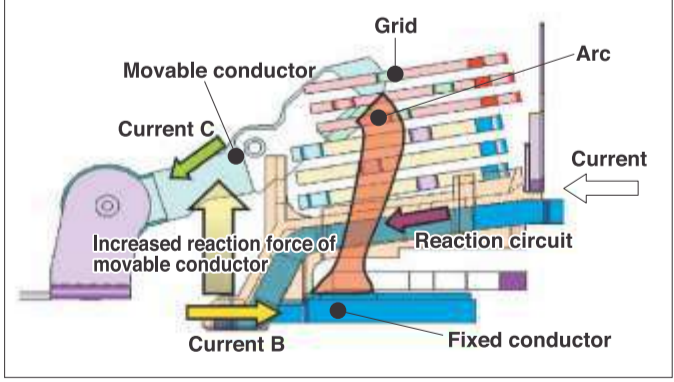

Current Limiting Performance

## Modular accessories

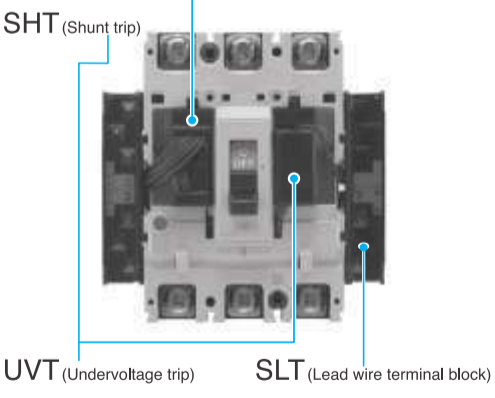

## FINAL DISTRIBUTION PRODUCTS

**DIN**  
Series



### PRODUCT LINE-UP

Model type	No of poles (P)	Rating	Instantaneous tripping	Voltage (V)	Short-Circuit capacity (kA)	Compliance standard	
MCB	BHW-T10	1, 1+N, 2, 3, 3+N, 4	6 to 63A	TYPE B	240/415AC	10 (Icn)	IEC 60898-1
		1, 1+N, 2, 3, 3+N, 4	0.5 to 63A	TYPE C, D	240/415AC	10 (Icn)	IEC 60898-1
		1, 1+N, 2, 3, 3+N, 4	80 to 125A	TYPE B*,C	240/415AC	10 (Icn)	IEC 60898-1*
RCCB	BVW-T	2(1+N), 4(3+N)	10 TO 100A	–	240/415AC	10 (Icn)	IEC 61008-1
Isolating Switch	KBW-T	1, 2, 3, 4	25, 40, 63A	–	240/415AC	–	IEC 60947-3
		2, 3, 4	80, 100, 125A	–	240/415AC	–	IEC 60947-3

\*This standard will be confirmed shortly please contact our branch office for release period and more details.

### Technical Specifications

Ambient temperature range	-10 to +40
Frequency	50/60Hz



- SPN Horizontal Door Distribution Board-04 way to 16 way
- TPN Horizontal Double Door Distribution Board-04 way to 16 way
- VTPN Distribution Board with Miniature Circuit Breaker (upto 63A) as incomer-04,08,12 way
- VTPN Distribution Board with Moulded Case Circuit Breaker (upto 250A) as incomer-04,08,12 way
- Flexi (Tier) Distribution Board 2 Row/ 3 Row/ 4 Row-upto 13 module per Row
- Seven segment Distribution Board-04 way to 12 way
- Per Phase Isolation Distribution Board-04 way to 12 way
- TPN Phase Selector Distribution Board-04 way to 12 way
- Plug and Socket Distribution Board-SPN-10A, 20A and TPN-20A,30A
- Cable End Box Distribution Board



## MAGNETIC CONTACTORS AND MAGNETIC STARTERS

**MS-T** Series  
**MS-N** Series

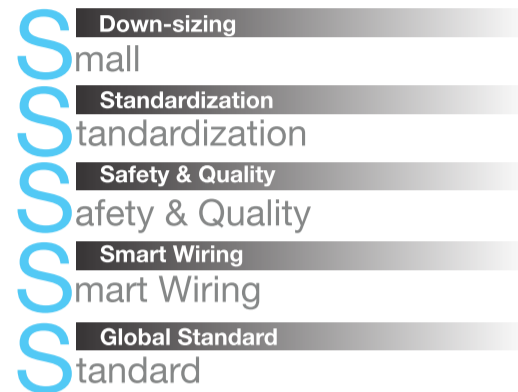

### Easy Branch Circuit Wiring with Manual Motor Circuit Breaker and optional connection Conductor Unit

Easy wiring is available for the new MS-T Series by using the Manual Motor Circuit Breaker and optional connection Conductor Unit, contributing to increased productivity.

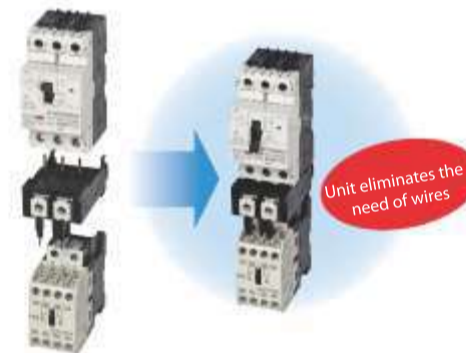

### Magnetic Contactors



**Product Range**  
9A-800A  
**Operating Voltage**  
280-440 V AC (50/60 Hz)  
**Integrated Auxiliary Contacts**  
1-4 (NO and/or NC)

### Motor Protection Circuit Breaker



**Product Range**  
0.1A to 32A  
**Operating Voltage**  
200-690 V AC (50/60 Hz)

### Additional Product offering

- Solid State Time Delay Relays
- Pneumatic Time Delay Relays
- Electronic Motor Protection Relay
- Thermal Motor Protection Relay
- Voltage Detection Relays
- Restarting Relays
- Solid State Contractors
- DC Contractors
- DC Interface Contractors
- Medium Voltage Vacuum Contractors

# ENERGY MONITORING SOLUTIONS

## ① ME96SSHA-MB (High-Performance Model)

### Major features

- [1] Active energy measuring accuracy of class 0.5S
- [2] Applicable to harmonics of  $\pm 1.0\%$  (31st)
- [3] Applicable to demands A and W, var, VA
- [4] Optional units can be added.



## ② ME96SSRA-MB (Standard Model)

### Major features

- [1] Active energy measuring accuracy of class 0.5S
- [2] Applicable to harmonics of  $\pm 1.0\%$  (19th)
- [3] Applicable to demands A and W, var, VA
- [4] Optional units can be added.

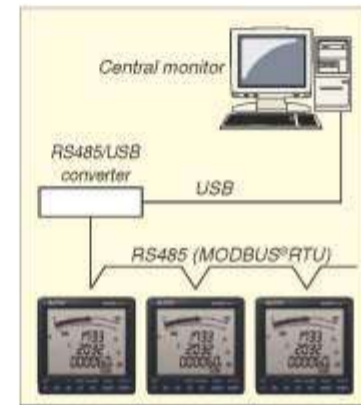

## ③ ME96SSEA-MB (Economy Model)

### Major features

- [1] Active energy measuring accuracy of class 0.5S
- [2] Applicable to harmonics (THD)
- [3] Applicable to current demand

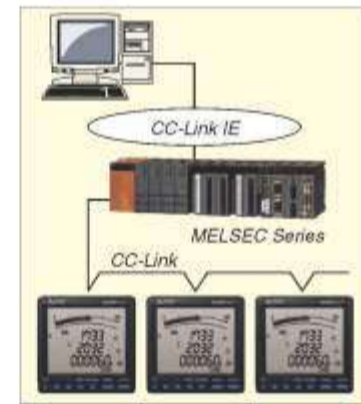

## ④ Optional plug-in modules

### Major features

- [1] MODBUS<sup>®</sup> TCP communication unit **NEW**
- [2] Data logging unit **NEW**
- [3] CC-Link communication unit
- [4] Digital input and output unit
- [5] Analog, pulse and alarm output unit

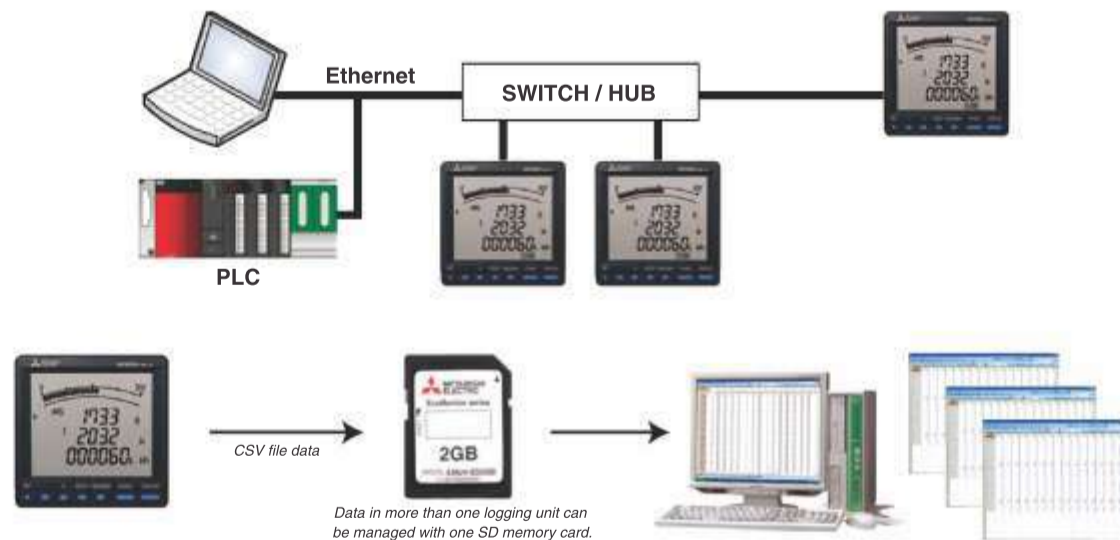

Data in more than one logging unit can be managed with one SD memory card.  
 Note: Use the SD memory card (EMU4-SD2GB) made by Mitsubishi Electric.  
 Use of any memory card other than our product (EMU4-SD2GB) is not covered by the warranty.

## Related Products



### ‡EcoWebServerIII

Mitsubishi Electric Energy-saving Data Collection Server  
From visualization to publication of energy data

#### Simple Set-up

When using the set-up software supplied, power management meters connected to CC-Link and measurement data can be set by mouse and keyboard operations.

#### Display Measurement Data as Graphs on a Web Browser

The main unit has a built-in web server that allows anyone, anywhere to understand the amount of energy being used in real time via computer without requiring additional software, thereby supporting early detection of energy waste.

#### Automatic Transmission of Data Collected, Mail Notifications and Contact Output

Users are notified of changes in energy, facilities, etc. via e-mail and alarms. Energy management targets and status monitoring of entire factories and buildings help ensure that problems onsite are detected without fail.

- ◇ PLC data can also be sent to EcoWebServerIII by Ethernet.
- ◇ Data of various sites can be browsed in the head office by utilizing the internal network.

Collection, storage, visualization,  
publication on the web, analysis and monitoring  
All can be realized by one server.



### ‡EcoMonitorPlus

Energy measuring units helpful in adding units for increased number of measuring circuits and preventive maintenance by simultaneous measurement of electric power and leakage

#### Phased expansion of energy-saving system

At first, energy-saving measurement can be started on a small scale from a desired place. The system can be configured by adding units according to the increase of measuring circuits.

#### Leakage current monitoring

Lineup of basic units for monitoring insulation

Helpful in early detection of equipment problems through accurate leakage current trend monitoring by Ior method

\* Ior: Leakage current caused by insulation deterioration (leakage current of resistive component)

#### Simple management of measurement data with prepared forms and graphs

Data can be collected by the logging unit (SD memory card) without the host application on the PC, etc.

Forms and graphs can be easily prepared by using the spreadsheet software (logging unit utility\*).

\* The logging unit utility can be downloaded for free from Mitsubishi Electric FA site.

Energy Measuring Unit  
EcoMonitor Plus

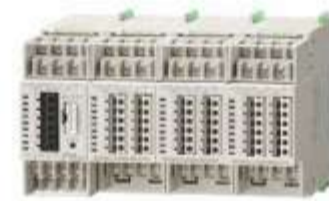

### ‡EcoMonitorLight

Energy measuring unit with integrated display for easily realizing the visualization of energy

A two-model line-up: a Three phase 3-wire system designed for users wanting simple power measurements at low cost; and a Three phase 4-wire system designed for users looking for basic power measurements plus something extra (harmonic measurements, alarm monitoring, etc.).

#### Simple Measurements

The built-in LCD enables easy setting, measurement and display of power used for energy management.

#### MODBUS® RTU (RS-485) Communication as Standard Equipment

Meters come with MODBUS® RTU communication as standard equipment, allowing the device to be used as a PLC system, other high-order system, display device (GOT), etc.

#### Logging/Communication Units for Expanded Measurement Applications

The product line-up also includes logging units/communication units (CC-Link communication unit) that can be incorporated as add-on options, enabling installations that best match to the customer's usage environment.

‡ Logging unit: Data measured by the main unit (current, voltage, power, etc.) can be output to an SD memory card in CSV file format, realizing simple data management.

#### Highly Accurate Measurements and Support Functions

Customer activities are supported through functions such as 250µs high-precision (short-cycle load) measurement, operating time measurement, wiring error detection and test output.

Energy Measuring Unit  
EcoMonitor Light



# ELECTRONIC MULTI-MEASURING INSTRUMENT

MODEL: EMMS7-96

## Product Outline

Highly appreciated 'Electronic Multi-Measuring Instrument' have been launched with economical version with seven-segment display. New EMMS7-96 meter with improved measurement function and MODBUS® RTU communication support.

It allows more effective energy monitoring function with seven-segment LED display, brilliant 3 Row, 4 digits per line LED display readable from larger distance having built-in MODBUS® RTU communication.

## Salient Features

- 7-segment bright red LED display; 3 rows of 4 digits
- Measurement of major electrical parameters and power quality
- User selectable phase wire system: 3-phase 4-wire, 3-phase 3-wire (3CT, 2CT), 1-phase 3-wire, 1-phase 2-wire
- User programmable CT/PT primary, CT/PT secondary
- Built-in RS-485 MODBUS® RTU communication
- Easy display navigation and settings

## Application Area

1. Control panels
2. Motor Control Centres (MCC)
3. Power distribution panels
4. Breaker panels
5. Original Equipment Manufacturers (OEMs)
6. Building Management Systems (BMS)
7. Genset panels

## User Benefits

- Multiple parameters monitoring for network reliability and diagnosis
- Reduce energy cost by tracking Energy consumption
- Basic power quality analysis with THD
- MODBUS® RTU communication system optimizes computer monitoring operations
- Remote monitoring of parameters A, DA, V, W, var, VA, Wh, varh, VAh, PF, Hz, harmonic voltage and harmonic current (Total)





## SPECIFICATIONS

Type		EMMS7-96EA-MB		
Phase Wire System		3-PHASE 4-WIRE, 3-PHASE 3-WIRE (3CT, 2CT), 1-PHASE 3-WIRE, 1-PHASE 2-WIRE		
Rating	Current	5A AC, 1A AC		
	Voltage	3-PHASE 4-WIRE: max 277/480VAC 3-PHASE 3-WIRE: (DELTA) max 220VAC, (STAR) max 440VAC 1-PHASE 3-WIRE: max 220/440VAC 1-PHASE 2-WIRE: (DELTA) max 220VAC, (STAR) max 440VAC		
	Frequency	50-60Hz		
Item	Measurement Item	Measurement Accuracy		
Measurement Elements	Current (A)	A1, A2, A3, AN, A <sub>AVG</sub>	±0.5%	
	Current Demand (DA)	DA1, DA2, DA3, DAN, DA <sub>AVG</sub>	±0.5%	
	Voltage (V)	V12, V23, V31, V <sub>AVG</sub> (L-L), V1N, V2N, V3N, V <sub>AVG</sub> (L-N)	±0.5%	
	Active Power (W)	W1, W2, W3, $\sum W$	±0.5%	
	Reactive Power (var)	var1, var2, var3, $\sum var$	±0.5%	
	Apparent Power (VA)	VA1, VA2, VA3, $\sum VA$	±0.5%	
	Power Factor (PF)	PF1, PF2, PF3, $\sum PF$	±2.0%	
	Frequency (Hz)	Hz	±0.5%	
	Active Energy (Wh)	Imported, Exported	Class1 (IEC62053-21)	
	Reactive Energy (varh)	Imported Lag, Imported Lead, Exported Lag, Exported Lead	Class2 (IEC62053-23)	
	Apparent Energy (VAh)	Imported + Exported	± 2.0%	
	Harmonic Current (HI)	Total	± 2.0%	
	Harmonic Voltage (HV)	Total	± 2.0%	
	Operation Time (h)	Operation time 1, Operation time 2	---	
Communication Specification		MODBUS <sup>®</sup> RTU communication		
Auxiliary Power		100-240VAC (±15%) 50-60 Hz, 100-240VDC (-30%, +15%)		
Weight		0.5kg		
Dimensions		96 (H) X 96 (W) X 88 (D)		
Operating Temperature / Humidity		-5 to +55°C (average temperature : 35°C or less per day), 0 to 85% RH, non condensing		
Storage Temperature / Humidity		-25 to +75°C (average temperature : 35°C or less per day), 0 to 85% RH, non condensing		

## DIMENSIONS AND WIRING DIAGRAMS

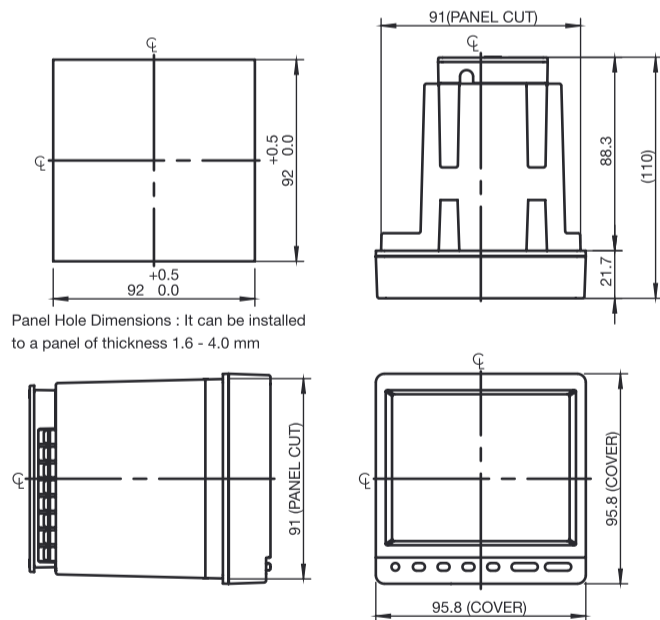

## 3P/3W and 3P4W / MODBUS<sup>®</sup> RTU COMMUNICATION

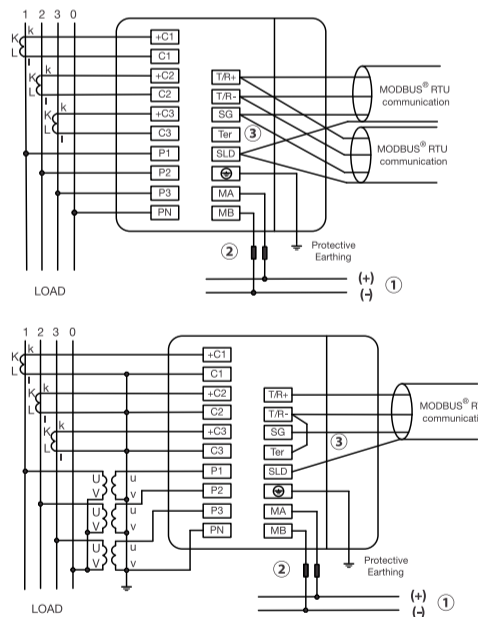

- ① Auxiliary power supply : AC100 to 240V or DC100 to 240V.
- ② Fuses 0.5A
- ③ Some MODBUS<sup>®</sup> RTU equipment doesn't have SG. In this case, the wiring between SG is unnecessary.
- # 1: For low voltage circuits, grounding the secondary side of VT and CT is not necessary.

for a greener tomorrow



**⚠ Safety Warning**

To ensure proper use of the products listed in this catalogue, please be sure to read the instruction manual prior to use.

**West Zone**

**Pune Head Office**

ICC-Devi Gaurav Technology Park, Unit no. 402, Fourth Floor, Opp. Vallabh Nagar Bus Depot, Pune – 411018, Maharashtra, India.  
Phone: +91 (20) 2710-2000

**Mumbai Office**

305-306, 3rd Floor, "Windfall", Sahar Plaza Complex, Next to Kohinoor Hotel, Andheri Kuria Road, J. B. Nagar, Andheri (E.) Mumbai-400 059, India  
Phone: +91 (22) 6611-6200  
Fax: +91 (22) 6611-6299

**Ahmedabad Office**

2nd floor, 31Five, Opp. Paladium, Near Vodafone House Corporate Road, Prahladnagar, Ahmedabad -380015  
Phone: +91 (79) 65120063

**Vadodara Office**

A-1/2, 2nd Floor, Status Plaza, Opp. Relish Resort Aksar Square, O.P Road, Vadodara -390020, India  
Phone: +91 (265) 231-4699/ 235-8137  
Fax: +91 (265) 233-3307

**Nagpur Office**

Plot No. 8, NIIT Layout, Ravindra Nagar, Ring Road, Nagpur - 440022, Maharashtra India.  
Phone: +91 (712) 228-4020

**North Zone**

**Gurgaon Office**

2nd Floor, Tower A & B, DLF Cyber Greens, DLF Cyber City, DLF Phase -III, Gurgaon-122002, India  
Phone: +91 (124) 463-0300 +91 (124) 673-9300  
Fax: +91 (124) 463-0399 / 398

**Jaipur Office**

Office No. 9B & 10, 4th Floor, C-44 Man Upasana Plaza, Sardar Patel Marg, C-Scheme, Jaipur-302001, Rajasthan, India  
Phone: +91 (141) 4011109

**Chandigarh Office**

SCO- 376, Second Floor, Sector 32 D, Chandigarh – 160036, Chandigarh, India.  
Phone: +91 (172) 4601645

**Indore Office**

110, 1st Floor, Shagun Commercial Complex, Plot No. 7/PU - 4, Scheme No. 54, Vijay Nagar, Indore - 452010, Madhya Pradesh, India  
Phone: +91 (731) 6050013

**Rudrapur Office**

181/6, Awas Vikas Ring Road, Udham Singh Nagar, Rudrapur - 263153, Uttarakhand, India.  
Phone: +91 (5944) 246899

**South Zone**

**Bangalore Office**

Esquire Centre, No.-9, Ground Floor, B-Block, Trinity Circle, MG Road, Bangalore-560001  
Phone: +91 (80) 4020-1600  
Fax: +91 (80) 4020-1699

**Chennai Office**

Isana Katima, 3rd Floor, Door No.497 & 498, Poonamallee High Road, Arumbakkam, Chennai-600 106  
Phone: +91 (44) 4923-2222  
Fax: +91 (44) 4923-2249

**Coimbatore Office**

(BMH srinivas) 2nd floor, Door no.1604 trichy road Coimbatore - 641018  
Phone: +91 (422) 438-5600

**Hyderabad Office**

5th Floor Imperial Towers, HNIS, 7-1-616 and 617/a, Ameerpet - 500 016, Telangana  
Phone: +91 (40) 4343-8888  
Fax: +91 (40) 4343-8899

**East Zone**

**Kolkata Office**

Plot – A3, 1st Floor, Infinity Think Tank, Tower –II, Block GP, Sector–V, Salt Lake, Kolkata – 700091, West Bengal, India.  
Phone: +91 (33) 65001375



**MITSUBISHI ELECTRIC INDIA PVT. LTD.**  
Factory Automation and Industrial Division

2nd Floor, Tower A & B DLF Cyber Greens, DLF Cyber City, DLF Phase -III, Gurgaon-122002,  
India Phone: +91 (124) 463-0300 +91 (124) 673-9300 Fax: +91 (124) 463-0399 / 398

Learn more at [www.MitsubishiElectric.in](http://www.MitsubishiElectric.in)